

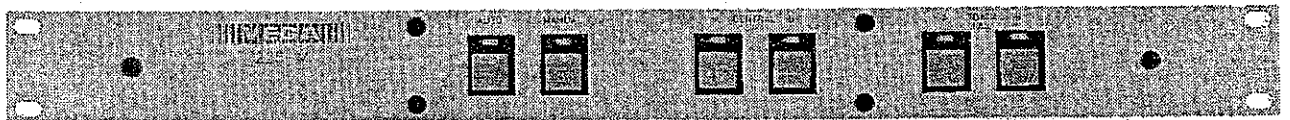

TELEX® Signaling Product Company

225-M Tone Remote Adapter Manual



Contents

1. Forward	3
2. General	3
3. Installation	4
3.1 Inspection.....	4
3.2 Mounting.....	4
3.3 Power.....	4
3.4 Fuse.....	4
4. Connections	5
4.1 External connectors.....	5
4.2 External connections.....	5
5. Operation	7
5.1 Description.....	7
5.1.1 Automatic Mode.....	7
5.1.2 Manual Mode.....	8
5.2 Operating capabilities.....	9
5.2.1 Relays.....	9
5.3 Controls and indicators.....	9
5.3.1 Relays.....	9
5.3.2 LED indications.....	9
5.3.3 Front panel pushbuttons.....	9
5.3.4 Mode Select Switch.....	9
5.3.5 Voltage Input Select Switch.....	9
5.3.6 Tuning jumper.....	9
Power Supply Schematic	10
Switch PCB Schematic	11
6. Theory Of Operation	12
6.1 General.....	12
6.2 Power-up conditions.....	12
6.3 Tone remote control.....	12
6.3.1 Detection Circuitry.....	12
6.3.2 Function tone detection.....	13
6.4 Logic control.....	14
6.4.1 TDATA signal input.....	14
6.5 Jumper settings.....	15
6.6 Automatic Mode Disable.....	15
225-M Parts Locator	16
225-M Schematics (1 of 3)	17
225-M Schematics (2 of 3)	18
225-M Schematics (3 of 3)	19
225-M Parts List	20
Vega Fax Library	22
Suggestions or Comments	23
Warranty (Limited)	23
Specifications	24

1. Forward

This manual is intended for use by experienced technicians familiar with similar types of equipment. All the information required for installation, operation, and servicing is included.

The manual is divided into sections for easy reference. Each section, although related, may be read independently without first reading the previous section.

2. General

The Vega 225-M is a tone remote adapter that switches between the two alarm units Central A and Central B. There are three ways in which one may switch between the alarm units. The first is by specific tone bursts, the second by manually pushing the appropriate button, and the third is through logic inputs. The 225-M runs in two modes - Automatic mode and Manual mode. These modes determine how alarm selection can be made. In Automatic mode the alarms may be switched by only the logic inputs. The manual mode allows alarm selection by either remote tone control or by pushing buttons on the front panel. Switching between Automatic and Manual control is done by remote tone control or by pushing the appropriate buttons on the front panel. The 225-M will power-up in the Automatic mode with Central A selected.

Tone remote control requires a 600 ohm voice grade or better line. Metallic or DC continuity is not required. If current is used on the line that the 225-M is connected to, DC blocking capacitors in series with the lines are required. The 225-M accepts the industry standard tone burst of 130ms of 2175 Hz at +10dBm as a guard/wake-up tone and 40ms of a function tone at +0dBm. No hold tone is needed.

Manual control uses four momentary pushbuttons on the front panel. They are labeled 'AUTOMATIC', 'MANUAL', 'CENTRAL A', and 'CENTRAL B'. The 225-M will power-up into the Automatic mode with Central A selected. To take manual control the Manual button must be pressed. The LED above the Manual button will light. This gives control to the Central A and Central B buttons.

Logic control is accomplished through J2 and J3, two 8 pin modular connectors available at the rear of the unit. The logic control inputs can be hooked to other circuitry for electronic control. A more detailed explanation is found in the theory of operation. Logic control is a switched option. The whole section of circuitry may be disconnected if desired.

The 225-M also has two modular connectors dedicated to inputs which are to provide pulses at least 360 times per second. If the 225-M does not receive these pulses it will initiate an alarm condition. This function is part of the logic control and will be enabled and disabled with the logic control section.

The 225-M gives control signals to the alarm units by means of dry contact closures.

3. Installation

3.1 Inspection

Carefully unpack the equipment and inspect it thoroughly as soon as possible after delivery. If any part of the equipment has been damaged in shipment report the extent of the damage to the transportation company immediately.

This unit has been inspected and adjusted to its recommended operating condition at the factory. Unless it has been handled roughly in shipment or otherwise abused or tampered with it will require only connections to be wired for operation.

3.2 Mounting

The 225-M is designed to mount in the industry standard 19 inch rack. The 225-M will fill one standard rack height (1.75").

3.3 Power

The 225-M requires an AC power source of 115VAC or 230VAC at 60 Hz. The internal power supply has a switch which allows 115VAC or 230VAC operation. Check the setting of this switch before applying power.

3.4 Fuse

A 1A, 250V 3AG slow-blow fuse is included with the unit. If there are problems in power-up verify that a working fuse is present.

4. Connections

4.1 External connectors

Connections to the 225-M take the form of RJ-45 eight conductor modular connectors. ~~The 225-M has seven of these connectors.~~

4.2 External connections

The following list gives the connector, the back panel label, and a brief description for each connection. J1-3, J1-5, J2-1, J2-3, J2-5, J3-1, J3-3, and J3-5 are designed to be controlled by open collector drivers or contact closures to ground. The inputs are pulled up to +9V through 10k resistors.

J1 - J1 is identified on the back panel as "SWITCH"

- 1 - Connected through a dry contact closure to J1-2 when CENTRAL A is active.
- 2 - Connected through a dry contact closure to J1-1 when CENTRAL A is active.
- 3 - A grounding of this pin will activate CENTRAL A when the 225-M is in the MANUAL mode.
- 4 - PCB ground
- 5 - A grounding of this pin will activate CENTRAL B when the 225-M is in the MANUAL mode.
- 6 - PCB ground
- 7 - Connected through a dry contact closure to pin 8 when CENTRAL B is active.
- 8 - Connected through a dry contact closure to pin 7 when CENTRAL B is active.

J2 - J2 is identified on the back panel as "CSC B"

- 1 - A0 of the logic comparator. This pin is shorted to PCB ground when CENTRAL A is active.
- 2 - PCB ground
- 3 - B2 of the logic comparator.
- 4 - PCB ground
- 5 - A1 of the logic comparator
- 6 - PCB ground
- 7 - A high voltage between 4 and 20 volts on this pin will connect J4-7 and J4-8 through a dry contact closure.
- 8 - A high voltage between 4 and 20 volts on this pin will connect J4-5 and J4-6 through a dry contact closure.

J3 - J3 is identified on the back panel as "CSC A"

- 1 - B0 of the logic comparator. This pin is shorted to ground when CENTRAL B is active.
- 2 - PCB ground.
- 3 - A2 of the logic comparator.
- 4 - PCB ground
- 5 - B1 of the logic comparator
- 6 - PCB ground
- 7 - A high voltage, between 4 and 20 volts, on this pin will connect J4-3 and J4-4 through a dry contact closure.
- 8 - A high voltage, between 4 and 20 volts, on this pin will connect J4-1 and J4-2 through a dry contact closure.

J4 - J4 is identified on the back panel as "AUX"

- 1 - Connected to J4-2 through a dry contact closure when a high voltage is applied at J3-8.
- 2 - Connected to J4-1 through a dry contact closure when a high voltage is applied to J3-8.
- 3 - Connected to J4-4 through a dry contact closure when a high voltage is applied to J3-7.
- 4 - Connected to J4-3 through a dry contact closure when a high voltage is applied to J3-7.
- 5 - Connected to J4-6 through a dry contact closure when a high voltage is applied to J2-8.
- 6 - Connected to J4-5 through a dry contact closure when a high voltage is applied to J2-8.
- 7 - Connected to J4-8 through a dry contact closure when a high voltage is applied to J2-7.
- 8 - Connected to J4-7 through a dry contact closure when a high voltage is applied to J2-7.

J5 - J5 is identified on the back panel as "TDATA A"

- 1 - TDATA_IN 1
- 2 - TDATA1_GND
- 3 - TDATA_IN 2
- 4 - TDATA2_GND
- 5 - TDATA_IN 3
- 6 - TDATA3_GND
- 7 - TDATA_IN 4
- 8 - TDATA4_GND

J6 - J6 is identified on the back panel as "TDATA B"

- 1 - TDATA_IN 5
- 2 - TDATA5_GND
- 3 - TDATA_IN 6
- 4 - TDATA6_GND
- 5 - TDATA_IN 7
- 6 - TDATA7_GND
- 7 - TDATA_IN 8
- 8 - TDATA8_GND

J7 - J7 is identified on the back panel as "REMOTE"

- 1 - Not used
- 2 - Not used
- 3 - Not used
- 4 - Line in high (balanced 600 ohm)
- 5 - Line in low (balanced 600 ohm)
- 6 - Not used
- 7 - Not used
- 8 - Not used

5. Operation

5.1 Description

Upon power-up the 225-M will be in the AUTOMATIC mode with CENTRAL A selected.

A slide switch (S1) on the main PCB allows the user to disable the Automatic mode by putting the switch into the B position.

5.1.1 Automatic Mode

In the AUTOMATIC mode the only way to change the CENTRAL settings is through the logic comparator section. The following chart shows the code structure.

INPUTS				
<u>A3,B3</u>	<u>A2,B2</u>	<u>A1,B1</u>	<u>A0,B0</u>	<u>ACTIVE CENTRAL</u>
A3>B3	ANY	ANY	ANY	B
A3<B3	ANY	ANY	ANY	A
A3=B3	A2>B2	ANY	ANY	B
A3=B3	A2<B2	ANY	ANY	A
A3=B3	A2=B2	A1>B1	ANY	B
A3=B3	A2=B2	A1<B1	ANY	A
A3=B3	A2=B2	A1=B1	A0>B0	B
A3=B3	A2=B2	A1=B1	A0<B0	A
A3=B3	A2=B2	A1=B1	A0=B0	A

The following chart defines A and B

<u>SIGNAL</u>	<u>PCB</u>	<u>BACK COVER</u>	<u>DESCRIPTION</u>
A0	J2.1	"CSC B" PIN 1	ACTIVE/IDLE B
A1	J2.5	"CSC B" PIN 5	MAJOR ALARM B*
A2	J3.3	"CSC A" PIN 3	MAJOR ALARM A
A3	TP2	Internal	TDATA A FAIL
B0	J3.1	"CSC A" PIN 1	ACTIVE/IDLE A
B1	J3.5	"CSC A" PIN 5	MAJOR ALARM A*
B2	J2.3	"CSC B" PIN 3	MAJOR ALARM B
B3	TP1	Internal	TDATA B FAIL

5.1.2 Manual Mode

The 225-M can be changed to the MANUAL mode by either a tone burst with an 1850 Hz function tone or by pressing the MANUAL button on the front panel. The 225-M is designed to accept tone bursts following the industry standard format guard tone (2175 Hz, 10dBm, 130ms) and a function tone (40ms, 0 dBm).

In the MANUAL mode the 225-M will change CENTRAL settings by tone bursts or by the front panel buttons. To set the 225-M to CENTRAL A a tone burst with a 1350 Hz function tone must be sent. To set the 225-M to CENTRAL B, a tone burst with 1250 Hz must be sent.

The following chart lists the function tone definitions

<u>Function tone</u>	<u>Effect</u>
1950 Hz	Changes 225-M to Automatic mode
1850 Hz	Changes 225-M to Manual mode
1350 Hz	Activate Central A
1250 Hz	Activate Central B

5.2 Operating capabilities

5.2.1 Relays

Relay outputs available to the external connectors can carry .5 Amps at 24V_{dc}.

5.3 Controls and indicators

5.3.1 Relays

Relays that are controlled by the AUX inputs of connector J4 require 4Vdc to 20Vdc for activation. Inputs below 4V may not activate the device and voltages above 20V may damage the device. Devices driving the AUX inputs must have a common ground with the 225-M. 225-M ground can be accessed through pins 2, 4, and 6 of the CSC B and CSC A modular connectors.

5.3.2 LED indications

LED indications are given for each panel button to show which mode the 225-M is in, which Central is active, and to give an indication of failure status from one of the TDATA inputs.

5.3.3 Front panel pushbuttons

Three pairs of buttons are on the front panel. The first pair select between the Automatic and Manual mode, the second pair selects which Central is active, and the third pair is used to reset the unit after a TDATA failure.

5.3.4 Mode Select Switch

The Mode Select Switch is a slide switch on the main PCB designated 'S1'. In the A position the 225-M will be able to function in the Automatic mode. When S1 is in the B position the 225-M is prevented from entering the Automatic mode.

5.3.5 Voltage Input Select Switch

The 225-M is designed to be able to accept power inputs of 115VAC and 230VAC. A slide switch on the power supply PCB controls which voltage is going to be accepted. The slide switch is clearly marked as to which setting is selected.

5.3.6 Tuning jumper

JP1 is a plug jumper on the main PCB which allows a technician to tune the function tone detectors on the main PCB. In the A position the function tone detectors require a 2175 Hz tone to be detected before audio is allowed to drive the function tone detector. It is in this position that the 225-M functions.

In the B position audio is fed directly to the function tone detectors. It is in the B position that the detectors are tuned. This jumper must be in the A position for proper 225-M field operation.

Power Supply Schematic

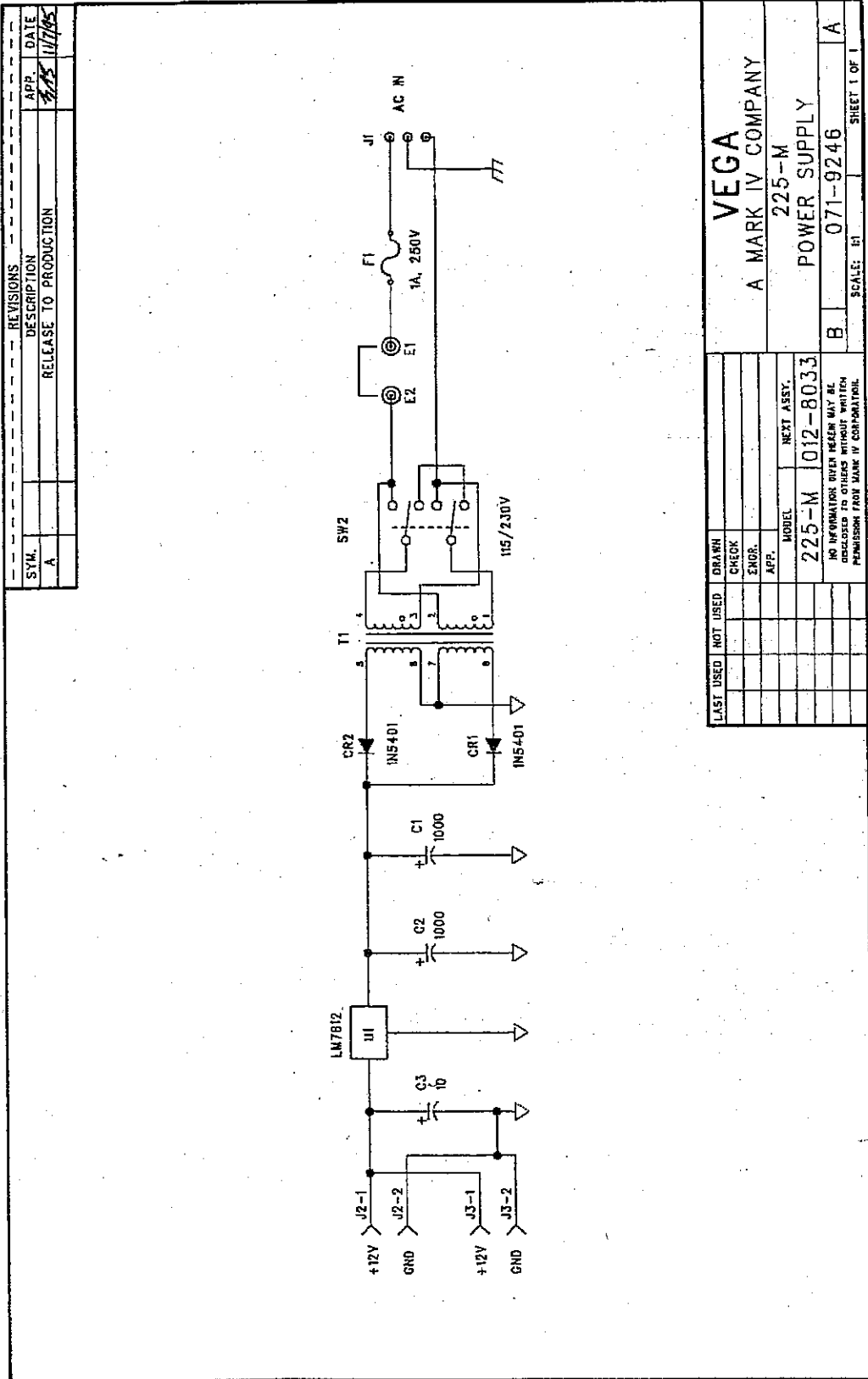

LAST USED	NOT USED	DRAWN	CHECK	ENGR.	APP.	MODEL	NEXT ASST.
						225-M	1012-8033

NO INFORMATION GIVEN HEREIN MAY BE DISCLOSED TO OTHERS WITHOUT WRITTEN PERMISSION FROM MARK IV CORPORATION.

Switch PCB Schematic

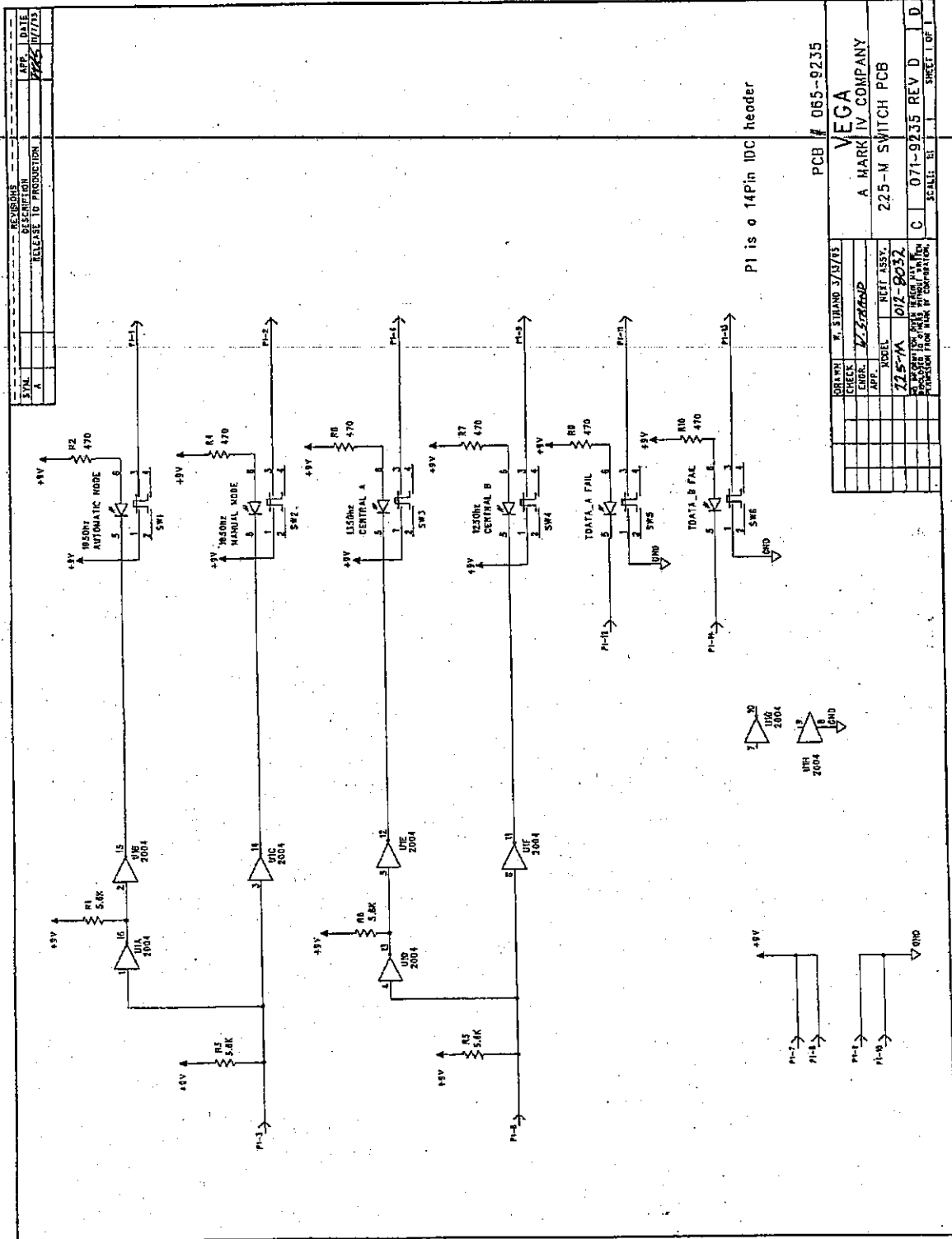

REV	DATE	DESCRIPTION
1	07/13	RELEASE TO PRODUCTION

DESIGN	DATE	BY	APP	MODEL	REV	ASST
775-M	07-90	ZZ	ZZ	225-M SWITCH PCB	D	

VEGA
A MARK IV COMPANY
225-M SWITCH PCB
PCB # 065-9235

REV	DATE	DESCRIPTION
C	071-9235	REV D
D		SHEET 1 OF 1

P1 is a 14Pin IDC header

6. Theory Of Operation

6.1 General

The 225-M was laid out for ease of testing. Each adjustment potentiometer has a test point that gives direct feedback. Potentiometers are placed in the circuitry for the optimal electronic response, but the associated test points are placed next to the potentiometers making it simple to adjust. Each potentiometer/test point pair is clearly labeled.

6.2 Power-up conditions

Upon power-up the 225-M will be set in the Automatic mode with Central A selected. The Automatic mode is selected by the resistor/capacitor combination of R90 and C33. Central A is selected by the resistor/capacitor combination of R101 and C34.

The TDATA failure latches are reset by holding the set pins of U26A and U26B low and holding the reset pins high during power-up. Using TDATA A as an example, power-up reset is described. When power is applied U26.4 (reset pin) is given an instantaneous high through C73. This line goes low as C73 charges until C73 has a 9 volt potential across it. R129 then holds the line low until power is lost again. While this is happening the set pin (U26.6) is held low by C86. C86 must be charged up before any high level signal can hold the latch in the SET state. A low at the Set pin and a high at the Reset pin fulfills the required RESET condition.

6.3 Tone remote control

The bulk of the 225-M circuitry consists of tone decode logic for remote control of the unit. Tone remote control of the 225-M requires a 600 ohm line connected to modular connector J5-4 and J5-5. This line connection is gas tube protected by GT2 for defense against lightning. A tone burst will pass through transformer T1. This transformer is a 7K:10K which, with R138, provides the 600 ohm line impedance. This transformer will attenuate the signal about 3dB. U22B (input op amp) will pick the signal up after the transformer. U22B amplifies the signal by 10dB once it is attenuated to the desired level by R141. The signal then branches off into two directions. One direction is to the 2175 Hz detection circuitry. The other direction is to the function tone detection circuitry.

6.3.1 Detection Circuitry

The 2175 Hz detection circuitry consists of three blocks. The first block is the prefilter, the second block is the 2175 Hz bandpass filters, and the third block is the logic block. The strategy is to filter the signal until only the 2175 Hz component remains. What remains of the signal after one prefilter and three state variable filters is fed to level detect circuitry. The level of the signal is compared to a preset reference. If the signal is strong enough to be considered the 2175 Hz tone the logic circuitry will monitor the signal for 50ms. If the signal stays strong for 50ms then the logic will allow the audio to the function tone block for decoding there. If the signal does not maintain the required level then the detection will be considered something other than the required 130ms, +10dBm 2175 Hz guard tone.

The first block is the 2175 Hz prefilter. Upon entering this block the signal will be subjected to pot R140 which will control the input level to the prefilter. The prefilter itself is a two-pole filter with a center frequency of about 2175 Hz. U23D is the main component of the prefilter. The output level of the prefilter is measured at TP15.

The second block is the main filtering stage. The signal is routed through three state variable filters tuned to 2175 Hz. The filters are designed for a 2175 Hz center frequency. A potentiometer is included in each filter to allow precise tuning to negate component tolerances. R116/TP14 adjusts the first bandpass filter. R67/TP11 the second and R53/TP10 the third bandpass filter.

The third block is the logic block which takes the signal that has made it through all the filters and rectifies it through CR5. The signal charges C20 to a point where it crosses the threshold set by the voltage divider circuit of R103 and R104. When this threshold is crossed U8A.1 will go low. This low will take about 50ms to discharge C38. When C38 has discharged to a point that crosses the threshold set by the voltage divider made by R61, R102, and R63 then schmitt trigger U8B.7 will slam high. This will trigger the U18A timing circuit which will turn analog gate U21A on and allow audio to the function tone detect circuitry for 200ms. Should the signal lose strength and U8A.1 go high before C38 can be discharged below the schmitt trigger threshold then the detect system will be reset and require another signal for the full 50ms term.

6.3.2 Function tone detection

Once a valid 2175 Hz guard tone is detected audio gate U21A will allow the line audio through to amplifier U20A which will distribute the audio to the four different function tone decoders for approximately 200ms. This time allows the remainder of the guard tone and the full function tone through.

If the function tone is 1950 Hz then TP1950 will go low which will reset U19A through U14C. Resetting U19A will change from the MANUAL mode to the AUTOMATIC mode. This will light the AUTOMATIC button's LED on the switch PCB and disable all forms of switching the CENTRAL setting except for the logic control. The tone remote and switch panel are incapacitated by a low signal from flip-flop U19A.1 to AND gates U12D.13 and U12B.5. The high on U19A.2 enables logic control by activating AND gates U12C.9 and U12A.2.

If the function tone is 1850Hz TP1850 will go low and will set U19A through U14B. Setting U19A will change from AUTOMATIC mode to MANUAL mode. The LED in the MANUAL button on the switch PCB will light and configuration power will be given to the tone remote and to the switch PCB by a high on U19A.1 to AND gates U12D.13 and U12B.5. Configuration power will be taken away from the logic section by a low from U19A.2 to AND gates U12C.9 and U12A.1.

If the function tone is 1350 Hz then TP1350 will go low which will apply a high logic level to AND gate U12B.6 through U15A. If the 225-M is in the MANUAL mode then a high logic level signal will be at the other input of AND gate U12B. Two high levels will produce a high at U12B.4 and reset U19B through U15C. Resetting U19B will deactivate relay K5. This initiates the CENTRAL A setting.

If the function tone is 1250Hz then TP1250 will go low which will apply a high logic level to AND gate U12D.12 through U15B. If the 225-M is in the MANUAL mode then U12D.13 will be high and this will send a high logic level from U12D.11 through U14A to U19B.8. This will set flip-flop U19B. Setting flip-flop U19B will activate relay K5. This initiates the CENTRAL B setting.

6.4 Logic control

The third way of changing configuration is through a logic comparator. This comparator compares inputs A0, A2, and A3 to B0, B2, and B3.

If the binary number represented by the A group is greater than the B group then comparator output U16.5 will go high. This signal will go through switch S1 to AND gate U12C. If the 225-M is in the AUTOMATIC mode then a high will be present at U12C.8. This will produce a high signal at U19B.8 through U14A. This will activate CENTRAL B.

If the binary number represented by the B group is greater than the A group then comparator output U16.7 will be high. This high will go through switch S1 to AND gate U12A.2. If the 225-M is in the AUTOMATIC mode then a high will be present at U12A.1. This produces a high at U12A.3 through U15C to U19B.10 which will reset U19B. This will activate CENTRAL A.

If the binary number represented by the A and B groups are equal then the comparator will default to the CENTRAL A setting.

6.4.1 TDATA signal input

The TDATA monitoring circuitry provides a sort of 'watchdog timer'. Oscillator U30 will divide a 1.8432M Hz crystal by 1024 and produce a stable 1800 Hz output square wave. Both Centrals have count-down chips (U24 for A; U25 for B) which will count ten of the 1800 Hz pulses. When the count-down chip reaches the tenth pulse it will initiate an alarm condition. The only thing that will prevent this from happening is a reset pulse from the TDATA inputs. The following explanation is for TDATA A. The TDATA B circuitry is identical.

U24 accepts the 1800 Hz clock input and counts the number of pulses. When ten pulses are counted the output pin U24.13 will go high. This high will be applied to the data input of a D-flip/flop which is clocked by the same 1800 Hz clock line. The 11th clock pulse will clock in the now high data and set the Q output U26.1. The LED of the front panel button TDATA_A will light and comparator U16 will switch to Central B. Once set only a manual pressing of the TDATA_A button and a resuming of reset pulses will end the failure status.

Reset pulses are the only thing that will prevent the count-down chip from initiating a failure status. Each Central has a four input modular connector which reset pulses must be applied. To use input #1 a square wave of 9V peak to peak is applied to J5.1 and J5.2. These pulses will create a high pulse at U29.1 which will reset the count-down chip. The count-down chip will start counting over. The reset pulses must come at least 360 times a second to effectively keep the 225-M from declaring failure status.

When the Mode Select Switch (S1) is in the B position a failure on the TDATA inputs will not switch the Central setting. The failure will activate the front panel failure status LED no matter what position S1 is in.

6.5 Jumper settings

JP1:A - In the A position received audio is not input to the function tone detectors until a 2175 Hz tone is detected. Once the 2175 Hz detection circuitry indicates a valid 2175 Hz tone has been detected it will activate analog gate U21 which will allow audio through to be checked for a valid function tone.

JP1:B - In the B position receive audio bypasses analog gate U21 and is fed directly to the function tone detectors. This setting is used only when tuning the function tone detectors. The jumper must be placed back in the A position when tuning is finished.

6.6 Automatic Mode Disable

The 225-M allows the user to enable and disable the Automatic mode. With the Automatic mode fully disabled the Centrals can not be switched by the logic inputs from CSC A and CSC B. The pushbutton on the front panel is also disabled so that the unit can not be left in Automatic mode accidentally. The unit will be locked in Manual mode. The Automatic mode is disabled when slide switch S1 on the main PCB is in the B position.

225-M Parts Locator

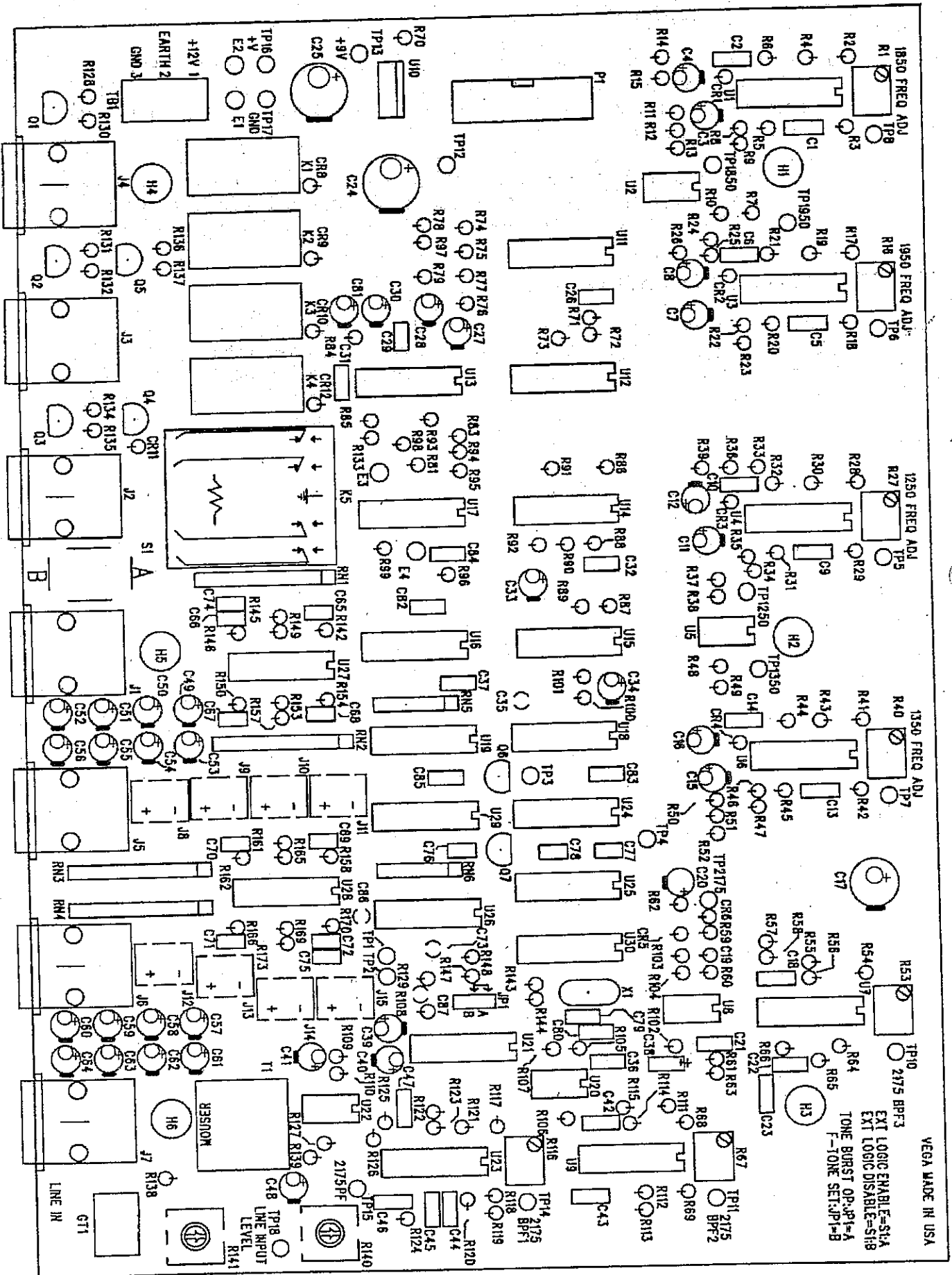

225-M Schematics (1 of 3)

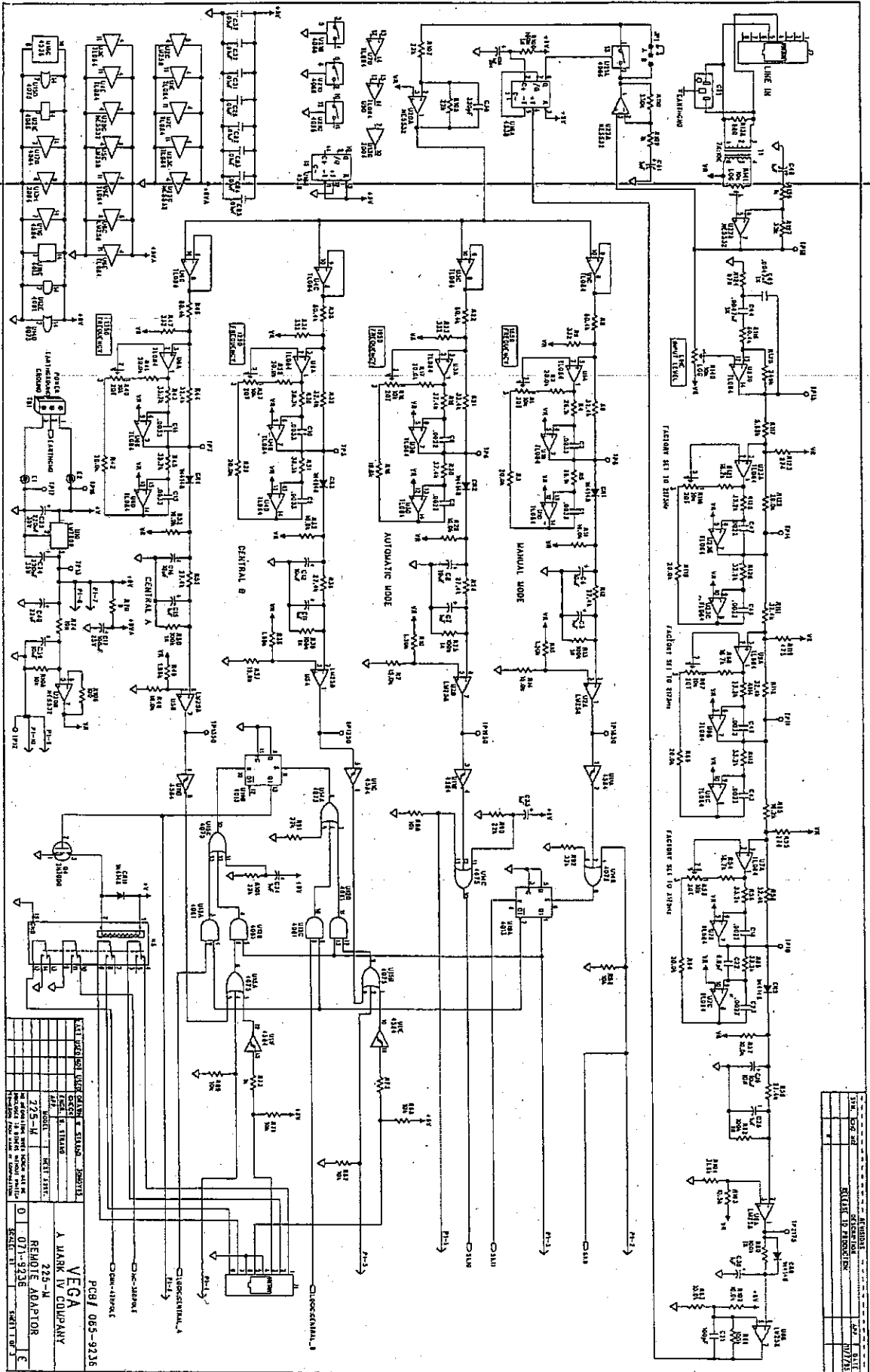

VEGA
 A HARRIS COMPANY
 225-M
 REMOTE ADAPTOR
 PCB / 065-9235
 REV. 1-75
 071-3138
 554

REVISIONS	
NO.	DESCRIPTION
1	ORIGINAL PRODUCTION
2	07/75

225-M Schematics (2 of 3)

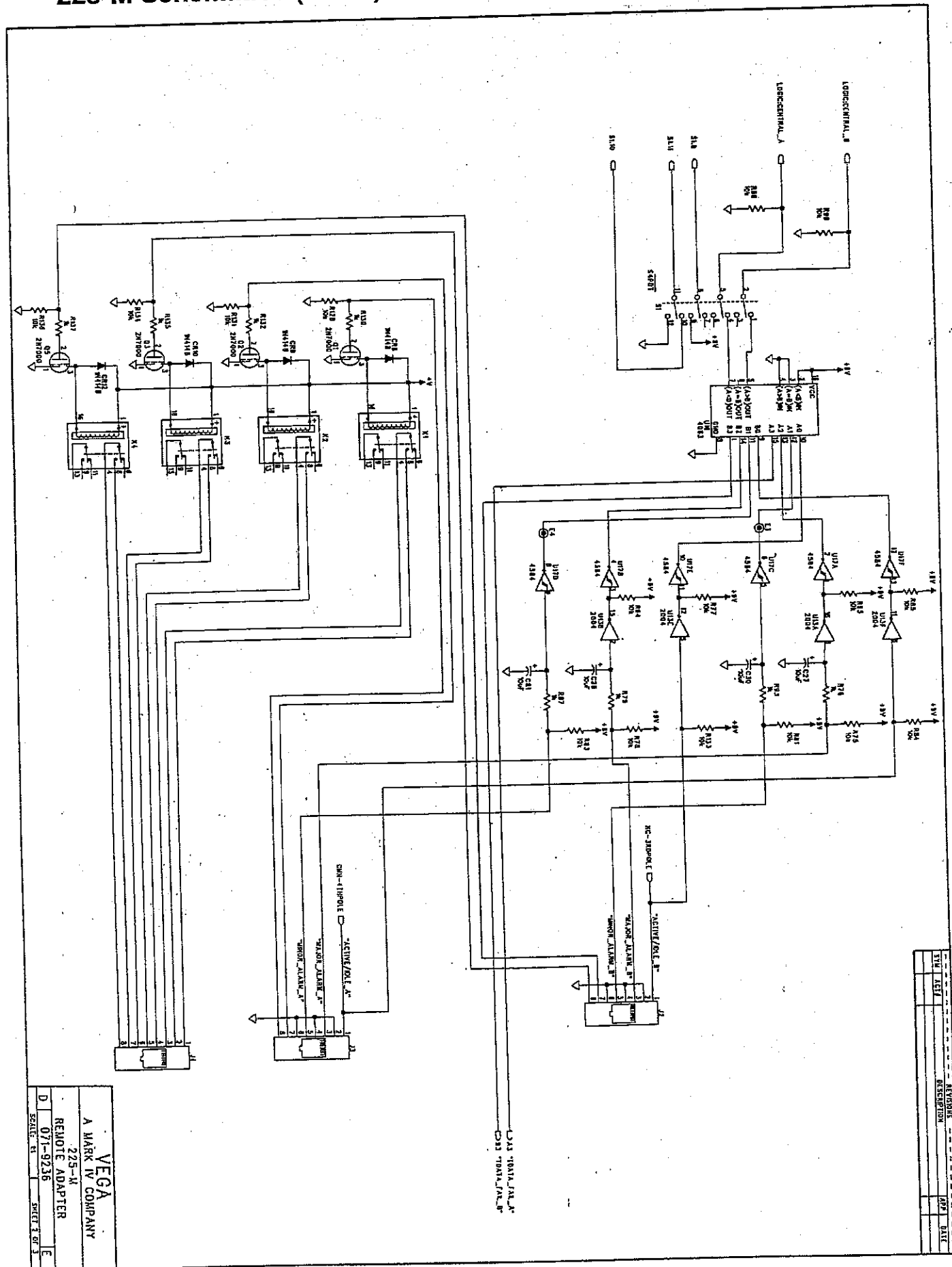

VEGA
A MARK IV COMPANY
225-M
REMOTE ADAPTER
D 071-9236 SHEET 2 OF 3
SCALE: N/A

REV	DATE	DESCRIPTION	APP	DATE

225-M Schematics (3 of 3)

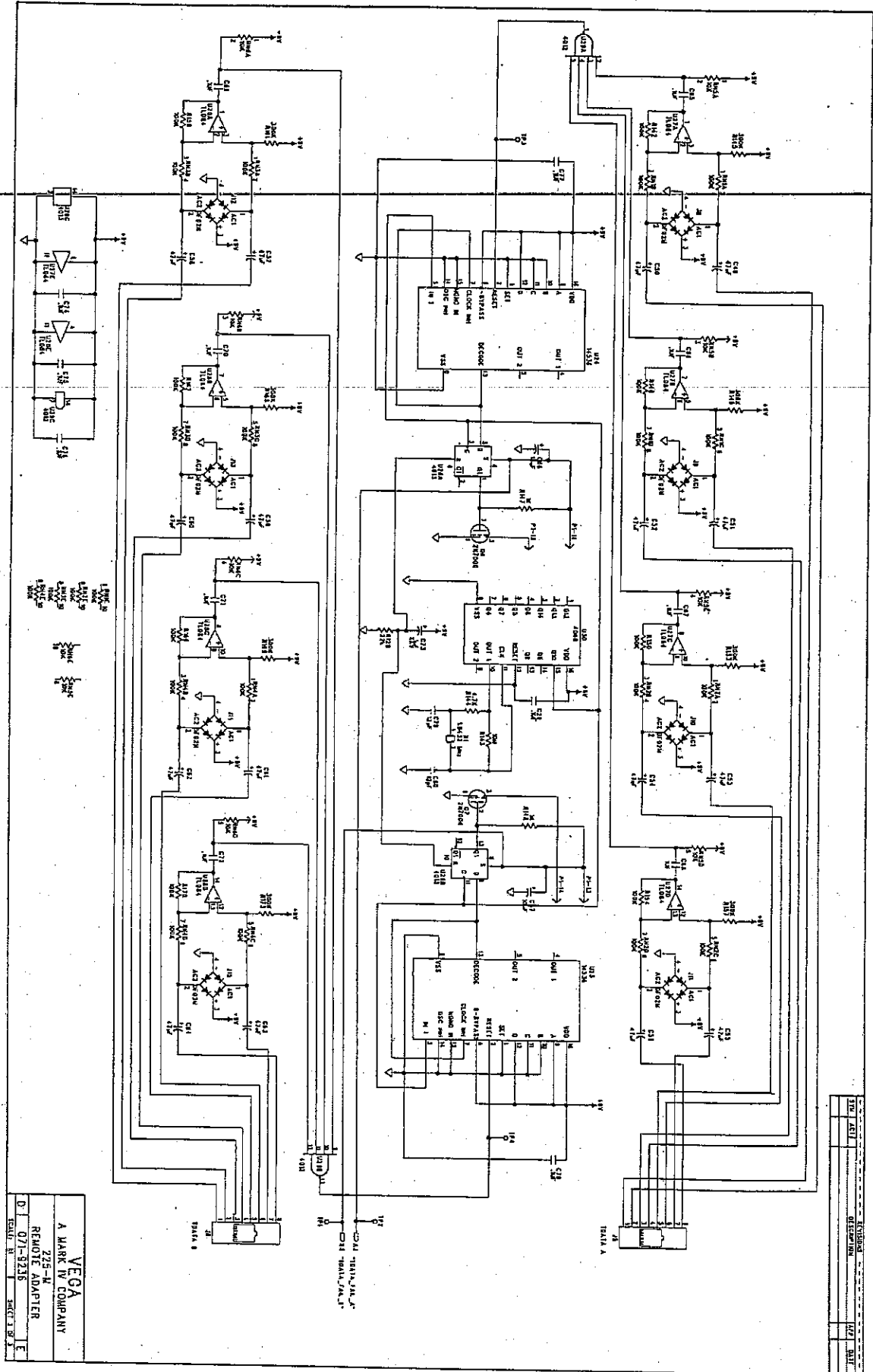

VEGA
A MARK IV COMPANY
225-M
REMOTE ADAPTER
D 071-5215
SCALE: 1/8"

REV	DATE	BY	CHK

225-M Parts List

VEGA PN	QTY	DESCRIPTION	REFERENCE DESCRIPTION
010-8033	1	225-M REMOTE ADAPTER	
011-8046	1	225-M ADPT REMOTE ASSY	
098-0359	1	MAN INST M-225	
674-0230	1	CORD AC POWER 3BLADE	
817-0453	1	CARTON 24*16*8 SELFLOC	
817-0457	2	KORRVU 24*16*4	
011-8046	1	225-M TOP ASSEMBLY	
012-8031	1	PCB ASSEMBLY 225-M MAIN	
012-8032	1	PCB ASSEMBLY 225-M SWITCH	
012-8033	1	PCB ASSEMBLY 225-M POWER	
021-9254	1	PANEL FRONT.	
021-9255	1	CASE	
021-9256	1	COVER	
022-0614	1	HEAT SINK	
286-1880	2	CONNECTOR, 14 POS IDC	IDC RIBBON CABLE IS 7" LONG
484-0123	1	INSULATION TAB	HEAT SINK ASSEMBLY
484-0126	1	TO-220 MICA INSULATION	HEAT SINK ASSEMBLY
517-0207	8	NYLON SPACER FOR SWITCH PCB	TWO SPACERS FOR EACH PEM STUD
527-0255	1	SCREW BLACK FH 4-40x3/16	HEAT SINK ASSEMBLY
527-0264	5	SCREW BLACK FH 6-32x3/8	SIDES AND TOP
527-0266	6	SCREW BLACK FH 8-32x3/8	FRONT PANEL
528-0002	1	SCREW PH 4-40x3/16	HEAT SINK ASSEMBLY
528-0003	10	SCREW PH 4-40x1/4	
528-0239	2	SCREW PH 4-40x3/8 BLK	
538-0075	16	NUT KEP 4-40	PCB MOUNTING
012-8031	1	PCB ASSEMBLY 225-M MAIN	
065-9236	1	225-M MAIN PCB	
102-0072	1	CAP CER 6.8pF	C22
102-0290	1	CAP CER 100pF	C21
104-0748	1	CAP TANT 10uF AXIAL	C19
104-0767	3	CAP TANT 1uF 10%	C35 C38 C87
104-0768	2	CAP TANT 10uF 10%	C73 C86
105-1116	2	CAP MYLAR .0047uF	C44-45
110-1319	8	CAP CER .01uF	C26 C31-32 C37 C82-85
110-1340	15	CAP CER .1uF	C29 C65-72 C74-78
110-1345	8	CAP CER .0022uF NPO	C5-6 C18 C23 C42-43 C46-47
110-1362	6	CAP CER .0033uF NPO	C1-2 C9-10 C13-14
110-1368	1	CAP CER 330pF	C36
110-1466	2	CAP CER NPO 12pF	C79-80
112-1606	9	CAP ELECT 10uF	C4 C8 C12 C16 C27-28 C30 C39 C81
112-1608	9	CAP ELECT 1uF	C3 C7 C11 C15 C20 C33-34 C41 C48
112-1609	1	CAP ELEC 100uF 20% 25V	C17
112-1613	2	CAP ELECT 220uF 20%	C24-25
112-1653	16	CAP ELECT 47uF	C49-64
112-1671	1	CAP ELECT 22uF	C40
130-0673	7	POT 10k 20T VADJ	R1 R16 R27 R40 R53 R67 R116
130-0724	2	RES VAR SQU 10k LOG	R140-141
132-0009	1	RES 0 ohm 1/4W	R70
134-0195	8	RES 100k 1% 1/4W	R13 R25 R39 R50 R60-62 R100
134-0212	7	RES 10.0k 1% 1/4W	R11 R26 R33 R52 R57 R63 R102
134-0233	2	RES 1.30k 1% 1/4W	R10 R15
134-2788	2	RES 37.4k 1% 1/4W	R19-20
134-2837	4	RES 15.0k 1% 1/4W	R7 R14 R37 R48
134-2840	1	RES 5.62k 1% 1/4W	R117
134-2847	7	RES 32.4k 1% 1/4W	R6 R21 R32 R44 R58 R111-112
134-2849	1	RES 19.6k 1% 1/4W	R18
134-2852	1	RES 16.2k 1% 1/4W	R65
134-2859	2	RES 35.7k 1% 1/4W	R43 R45
134-2877	11	RES 20.0k 1% 1/4W	R2-3 R17 R28-29 R41-42 R64 R69
134-2886	4	RES 332 1% 1/4W	R118 R122
134-2887	5	RES 27.4k 1% 1/4W	R9 R23 R34 R47
			R12 R24 R36 R51 R59

134-2892	5	RES 60.4k 1% 1/4W	R8 R22 R35 R46 R119
134-2923	2	RES 26.1k 1% 1/4W	R4-5
134-2947	1	RES 249k 1% 1/4W	R120
134-2960	2	RES 38.3k 1% 1/4W	R30-31
134-2991	1	RES 10.5k 1% 1/4W	R103
134-3020	2	RES 1.69k 1% 1/4W	R38 R49
134-3021	1	RES 475 1% 1/4W	R115
134-3023	3	RES 18.7k 1% 1/4W	R54 R68 R121
134-3036	2	RES 274 1% 1/4W	R55 R123
134-3038	1	RES 976 1% 1/4W	R124
134-3042	1	RES 31.6k 1% 1/4W	R104
134-3080	6	RES 33.2k 1% 1/4W	R56 R66 R113-114 R125-126
136-0020	1	RES 100 5% 1/4W	R106
136-0030	1	RES 680 5% 1/4W	R138
136-0032	12	RES 1k 5% 1/4W	R72-73 R76 R79 R93 R97 R109 R130 R132 R135 R137 R139 147-148 R144
136-0040	1	RES 4.7k 5% 1/4W	R71 R74-75 R77-78 R80-89
136-0044	26	RES 10K 5% 1/4W	R94-96 R98-99 R108 R128 R131 R133-134 R136
136-0048	7	RES 22k 5% 1/4W	R90-92 R101 R105 R107 R129
136-0050	1	RES 33k 5% 1/4W	R127
136-0056	8	RES 100K 5% 1/4W	R142 R146 R150 R154 R158 R162 R166 R170
136-0062	1	RES 330k 5% 1/4W	R110
136-0080	1	RES 10M 5% 1/4W	R143
136-1956	8	RES 300K 5% 1/4W	R145 R149 R153 R157 R161 R165 R169 R173
138-0016	4	RNET 10PN SIP ISO	RN1-4
138-0027	2	RNET 6PN SIP ISO	RN5-6
146-0005	1	GAS DISCHARGE TUBE	GT1
149-0642	7	2N7000 NMOSFET	Q1-7
161-0426	11	DIODE 1N4148	CR1-6 CR8-12
163-0002	8	DIODE BRIDGE FULL WAVE 1A 200V	J8-15
165-1228	1	XTAL 1.8432MHz -40to+85	X1
180-0324	1	RELAY 4PDT 12V	K5
180-0329	4	RELAY PCB 12V DPDT MDX12	K1-4
286-1768	22	TEST POINT YELLOW BAND	TP1-8 TP10-18 TP1250 TP1350 TP1850 TP1950 TP2175
286-1772	1	JUMPER 3POSITION	JP1
286-1766	1	JUMPER PLUG	JP1
286-1786	1	TERMINAL STRIP 3POS	TB1
286-1979	1	HEADER IDC 14POS	P1
286-2013	7	CONN 8PIN MODULAR	J1-7
299-0627	1	4PDT SLIDE SWITCH	S1
318-0252	1	TRANSFORMER LINE 7KCT:10KCT	T1
425-0158	2	4013 DUAL D FLIP-FLOP	U19 U26
425-0171	1	4081 QUAD 2-INPUT AND	U12
425-0172	2	4075 TRIPLE 3IN OR GATE	U14-15
425-0206	2	4584 HEX SCHMITT TRIGGER	U11 U17
425-0215	1	ULN2004 SEPTAL DRIVER	U13
425-0285	1	4066 QUAD ANALOG GATE	U21
425-0296	1	4063 COMPARATOR	U16
425-0411	1	4538 DUAL MULTIVIBRATOR	U18
425-0531	1	7809 VREG 9V, 1A	U10
425-0532	1	4012 DUAL 4-INPUT NAND GATE	U29
425-0533	1	4060 BINARY COUNTER	U30
425-0534	2	14536 PROGRAMMABLE TIMER	U24-25
425-0535	9	TL084IN QUAD OP-AMP -40to+85	U1 U3-4 U6-7 U9 U23 U27-28
425-0536	2	NE5532 DUAL OP AMP -40to+85	U20 U22
425-0538	3	LM285 DUAL OP AMP -40to+85	U2 U5 U8
012-8032	1	225-M Switch Assembly	
065-9235D	1	225-M SWITCH PCB	
136-0028	6	RES 470 5% 1/4W	R2 R4 R7-10
136-0041	4	RES 5.6K 5% 1/4W	R1 R3 R5-6
286-1979	1	HEADER IDC 14 POSITION	P1
296-0622	6	PUSHBUTTON BLUE - RED LED	SW1-6
425-0215	1	ULN2004 SEPTAL DRIVER	U1
012-8033	1	225-M Power Supply	
066-0128	1	POWER SUPPLY PCB	

112-1553	2	CAP ELECT 1000uF 25V	C1 C2
112-1606	1	CAP ELECT 10uF 25V	C3
163-0003	2	1N5401 DIODE 3A, 100V	CR1 CR2
261-0307	1	FUSE HOLDER	F1
261-0308	1	FUSE 1A SLO-BLO	
286-1889	1	CONNECTOR AC 90 DEG	J1
299-0324	1	SWITCH DPDT SLIDE (115/230)	S2
326-0493	1	X4MR WPR 24V CT 12VA	T1
425-0106	1	7812C 12VREG 1A	U1
475-1406	1	SOLDER LUG	
567-0363	1	SPOT TIE NYLON	
668-0023	3	WIRE GR/YE #20 600V	

Warranty, Service, Repair, and Comments

Important! Be sure the exact return address and a description of the problem or work to be done are enclosed with your equipment.

Warranty (Limited)

All Vega signaling products are guaranteed against malfunction due to defects in materials and workmanship for three years, beginning at the date of original purchase. If such a malfunction occurs, the product will be repaired or replaced (at our option) without charge during the three-year period, if delivered to the Telex factory. Warranty does not extend to damage due to improper repairs, finish or appearance items, or malfunction due to abuse or operation under other than the specified conditions, nor does it extend to incidental or consequential damages. Some states do not allow the exclusion or limitation of incidental or consequential damages, so the above limitation may not apply to you. This warranty gives the customer specific legal rights, and there may be other rights which vary from state to state.

Factory Service Center

TELEX Communications, Inc.

Vega Signaling Products

8601 East Cornhusker Highway, Lincoln, Nebraska, 68507

Phone: (402) 465-7026 / (800) 752-7560 Fax: (402) 467-3279

E-mail: vega@telex.com, Web: www.vega-signaling.com

Claims

No liability will be accepted for damages directly or indirectly arising from the use of our materials or from any other causes. Our liability shall be expressly limited to replacement or repair of defective materials.

Suggestions or Comments

We'd appreciate your input. Please send us your suggestions or comments concerning this manual, by fax (402-467-3279) or e-mail them to: vega@telex.com

Visit our web site at www.vega-signaling.com

Specifications

Electrical

Power requirements: 115VAC, 60 Hz or 230VAC, 60 Hz (selectable)

Operating temperature: -25C to +65C

Current draw: 400mA Max at 12V_{dc}

Line impedance: 600 ohm balanced

Detection bandwidth: PTT +/-100 Hz; F-tones +/-20 Hz

Detection sensitivity: PTT -55dBm; F-tones -35dBm

Relay ratings: .5A, 24V_{dc}

Relay control inputs: high logic level from 4V_{dc} to 20V_{dc}

TDATA inputs: peak to peak potential of 9V

Mechanical

19" x 1.75" x 8"

The 225-M is 19" rack mountable, one standard rack height, and 8" deep.



TELEX® Signaling Product Company

8601 East Cornhusker Highway, Lincoln, Nebraska, 68507
Phone: (402) 467-5321 / (800) 752-7560 Fax: (402) 467-3279
E-mail: don.poyas@telex.com, Web: www.vega-signaling.com