

Airman 8 ANR

Airman 8 ANR Headset



Table of contents

1	Record of revisions	5
2	Purpose of manual	6
2.1	Technical support	6
2.2	Parts ordering	6
2.3	Repairs	6
2.4	Safety precautions	7
3	Introduction	8
4	Parts list and exploded view	10
4.1	Exploded view	10
4.2	Parts list	11
5	Maintenance	14
5.1	Recommended maintenance schedule	14
5.2	Basic inspection	14
5.2.1	Physical inspection	14
5.3	Microphone troubleshooting	15
5.3.1	Validate continuity from plug to PCBA	16
5.3.2	Validate mic circuitry	16
5.3.3	Microphone/amplifier sensitivity test	16
5.3.4	Microphone sensitivity adjustment	16
5.3.5	Microphone total harmonic distortion (THD) test	17
5.4	Speaker troubleshooting	17
5.4.1	Speaker sensitivity and frequency response verification	17
5.4.2	Measure the resistance (plug to PCBA)	18
5.4.3	Validate the boom side PCBA	18
5.4.4	Validate the non-boom side PCBA	18
5.5	ANR troubleshooting	19
5.5.1	Measuring ANR circuit voltages and switch function	20
5.6	Cleaning the headset and connectors	21
5.7	Cleaning the ear cushions and headband pads	21
5.8	Replacing ear cushions and headband pads	21
5.9	Installing and replacing the hygienic covers	21
5.10	Replacing the windscreen	21
5.11	Headset storage	22
6	Disassembly	23
6.1	Remove the headband cover clips (if present)	23
6.2	Ear cushion replacement	24
6.3	Headband pad and headband pad replacement	24
6.4	Remove the mic prefilter	26
6.5	Remove the yoke assembly from the headband assembly	26
6.6	Boom side disassembly	27
6.7	Non-boom side disassembly	29
7	Assembly	33
7.1	Boom side assembly	33
7.2	Non-boom side assembly	38
7.3	Attach the prefilter	43
7.4	Reinstall the headband cover	43
7.5	Replace the yoke assembly on the headband assembly	43
8	Wiring Diagrams and Connectors	45

8.1	Wiring Diagram AIRMAN8-2010 and AIRMAN8-0211	45
8.2	PJ-068/PJ055 Connector Diagram for AIRMAN8-0210	45
8.3	XLR Connector Diagram for AIRMAN8-0210	46
8.4	Stereo Connector Diagram for AIRMAN8-0235	47

1 Record of revisions

Rev No.	Revision Date	Change Description
01	08/2018	Created
02	01/2019	Add CTS to Sec 2.4 Parts List
03	04/2022	Reformatted document
04	08/2022	Update missing content throughout all chapters.
05	08/2023	Remove Lincoln Nebraska address
06	10/2023	Added two entries for item 25, and add note 6 to explain the difference
07	01/2026	Updated Section 5.4.2 Added paragraph to 5.11

2 Purpose of manual

This manual contains information for overhaul and servicing of the Airman 8 headsets.

2.1 Technical support

A liaison between the customer and factory is provided by the Electro-Voice Dynacord Product Support Department. Consultation and assistance on technical problems, part information, and availability of local and factory repair facilities is available.

When writing, include all information concerning problems and mail to:

Electro-Voice Dynacord, LLC

Email: customerservice.aviation.nam@keenfinity-group.com

Attn: Aircraft Product Support Mgr.

Telephone: 877-863-4188

2.2 Parts ordering

Replacement parts may be ordered from our parts department. When ordering, please include the following information:

- Model Number
- Part Description
- Part Number
- Quantity

Mail to:

Electro-Voice Dynacord, LLC

Attn: **Parts department**

Telephone: 800-553-5992

Fax: 402-467-3279

E-mail: repairservice.nam@keenfinity-group.com

2.3 Repairs

In order to maintain the FAA certification, all repairs to the headset must be made only by persons authorized under Part 43 of the Federal Aviation Agency regulations. Electro-Voice Dynacord offers full support, repair, and recertification.

2.4 Safety precautions

**Caution!**

This information is for use by qualified personnel only. Have all service work and repairs performed by a trained technician.

- Unauthorized changes, modifications, or alterations to the product is prohibited.
-

**Caution!**

An ESD protection method should be applied before proceeding with any Mechanical/Electrical instructions.

**Caution!**

Use of any replacement part, which does not have the same specifications, may cause malfunction in the device and could make the product not air-worthy.

**Notice!**

Any material to be disposed of should be done according to local environmental laws.

3 Introduction

General Description

The Telex Airman 8 is a lightweight noise-reducing headset designed specifically for optimizing pilot communications in commercial and business turbine aircraft. Building on the tradition of the Airman 850, Airman 8 has improved durability, intelligibility, and comfort. The Airman 8 is among the lightest Active Noise Reduction headsets on the market and one of only three FAA TSO C139a approved ANR headsets to utilize Telex's proprietary battery-free system. Soft pliable ear cushions and headband pads combine with dual direction ear cup pivots to provide long flight wearing comfort.

Models Covered

Model Number	Description
AIRMAN8-0210	DOUBLE SIDE ANR HEADSET 2PJ 600 OHM
AIRMAN8-0211	DOUBLE SIDE ANR HEADSET XLR5 600 OHM
AIRMAN8-0235	DOUBLE SIDE ANR HEADSET 6-PIN STEREO

Table 3.1: AIRMAN 8 Models

Specifications



Notice!

This document uses FAA standard HATS (Head and Torso Setup) for specification measurement testing.

For current specifications, refer to the Airman 8 Technical Manual (F.01U.307.704) or the Airman 8 Technical Data Sheet (F.01U.307.701) located on the website.

Reference View



1. Headband Pad and Headband Pad Holder
2. Headset Gliders
3. Ear Cushions
4. Ear Cup Rotator
5. Boom Rotator
6. Cord with Strain Relief
7. Boom
8. Windscreen / Microphone

4 Parts list and exploded view

4.1 Exploded view

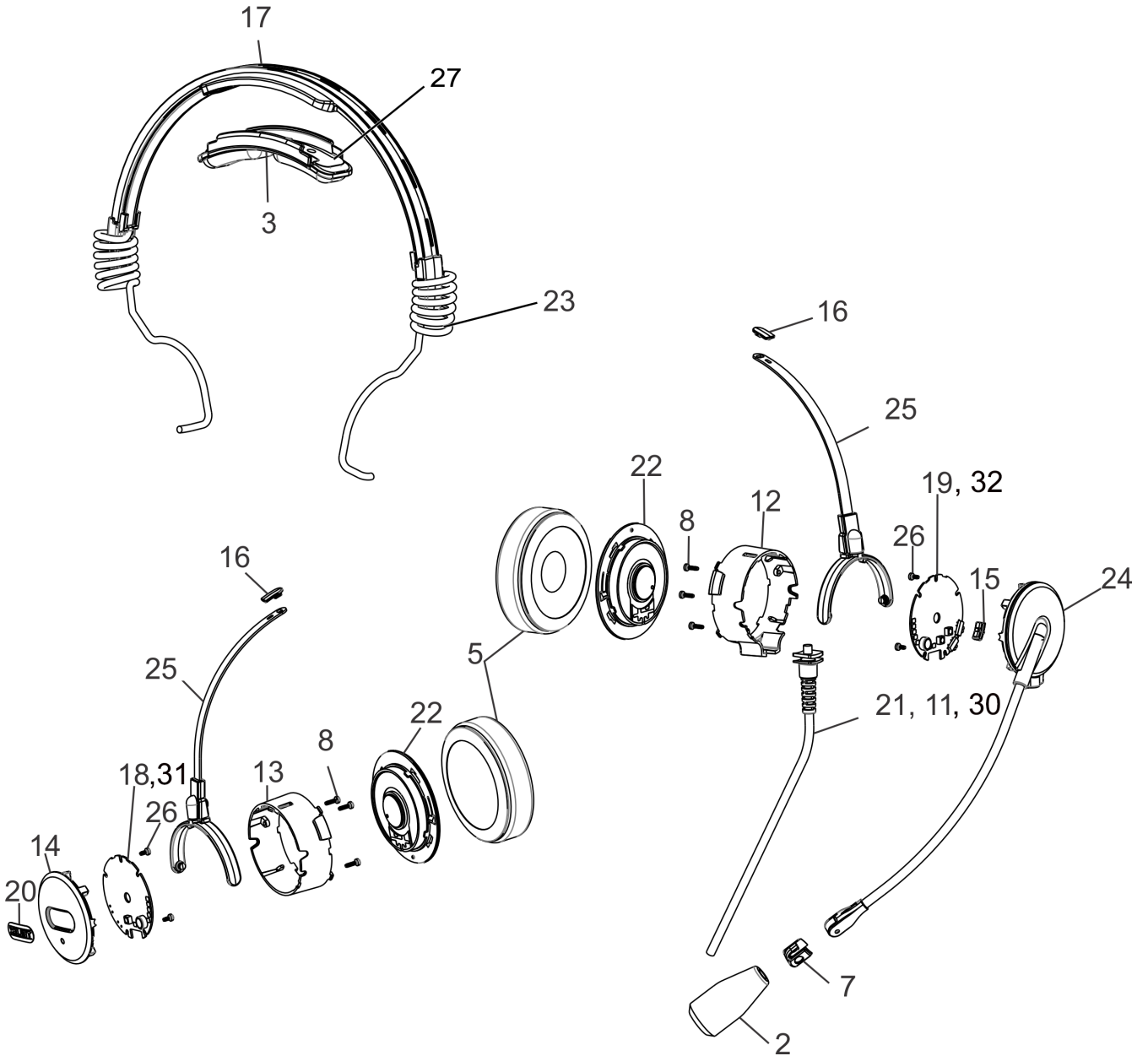

Figure 4.1: Airman 8 Basic Assembly

4.2

Parts list

ITEM	CTN	PART NO.	DESCRIPTION	MODEL		
				-0210	-0211	-0235
1 ^{1,2}	AIRMAN7-0905	F.01U.313.420	CARRYING CASE	1	1	1
	S-F01U342107	F.01U.342.107				
2 ²	AIRMAN7-0900	F.01U.313.415	WINDSCREEN (2PCS)	1	1	1
	S-F01U327249	F.01U.327.249	WINDSCREEN (SINGLE)			
3 ²	AIRMAN7-0906	F.01U.313.421	HEAD PAD	1	1	1
	S-F01U342089	F.01U.342.089				
4 ^{1,2}	AIRMAN8-0901	F.01U.313.996	SANITARY COVER, AIRMAN 8 (10PCS)			
	S-F01U342106	F.01U.342.106	SANITARY COVER, AIRMAN 8 (2PCS)			
5 ²	AIRMAN8-0900	F.01U.313.418	EAR CUSHION, AIRMAN 8 (2PCS)	1	1	1
	S-F01U342110	F.01U.342.110				
6 ^{1,2}	AIRMAN7-0904	F.01U.313.419	CLOTHING CLIP	1	1	1
	S-F01U342113	F.01U.342.113				
7 ^{2,3}	AIRMAN7-0908	F.01U.344.857	MIC PREFILTER	1	1	1
	S-F01U346184	F.01U.346.184				
8 ¹	590404360	F.01U.109.816	SCREW, PT, PAN HEAD, K15 X 6MM, BLK ZINC	6	6	6
9 ¹	54857101	F.01U.150.106	WIRE 28 AWG 212 WHITE	2	2	2
10 ¹	54857103	F.01U.150.110	WIRE 28 AWG RED	2	2	2
11	S-F01U342083	F.01U.342.083	CORD UNIT, PJ Y-BLOCK	1		
12	S-F01U342084	F.01U.342.084	EAR SHELL, BOOM SIDE, AIRMAN 8	1	1	1
13	S-F01U342085	F.01U.342.085	EAR SHELL, NON BOOM SIDE, AIRMAN 8	1	1	1
14	S-F01U342086	F.01U.342.086	COVER, NON BOOM SIDE, AIRMAN 8	1	1	1
15	S-F01U342087	F.01U.342.087	SWITCH ACTUATOR, AIRMAN 8	1	1	1
16	S-F01U342088	F.01U.342.088	GLIDER STOP (2PCS)	1	1	1

ITEM	CTN	PART NO.	DESCRIPTION	MODEL		
				-0210	-0211	-0235
17	S-F01U342090	F.01U.342.090	HEADBAND COVER	1	1	1
18	S-F01U342094	F.01U.342.094	PCBA, NON BOOM SIDE, AIRMAN 8	1	1	
19	S-F01U342096	F.01U.342.096	PCBA, BOOM SIDE, AIRMAN 8	1	1	
20	S-F01U342097	F.01U.342.097	LABEL, TELEX	1	1	1
21	S-F01U344915	F.01U.344.915	CORD UNIT, XLR, 5M		1	
22 ⁴	S-F01U344917	F.01U.344.917	SPEAKER ASSY, AIRMAN 8 (including faceplate)	2	2	2
23	S-F01U344918	F.01U.344.918	OVER HEAD CABLE	1	1	1
24	S-F01U344922	F.01U.344.922	BOOM MIC ASSY, AIRMAN 8	1	1	1
25 ⁶	S-F01U344923	F.01U.344.923	SPA Yoke glider assembly 180° rotation	2	2	2
	ESP-F01U360396	F.01U.383.835	SPA Yoke glider assembly 10° rotation	2	2	2
26 ¹	S-F01U344924	F.01U.344.924	SCREW, PT PAN HEAD K15 X 3.5MM (25PCS)	4	4	4
27	ESP-F01U351884	F.01U.359.827	HEADBAND PAD HOLDER	1	1	1
28 ^{1,5}	S-F01U347879	F.01U.347.879	HEADBAND CLIP (2 PCS)			
29 ¹	S-F01U348100	F.01U.348.100	HEADBAND COVER AND HEADBAND PAD			
30	F.01U.359.673	NA	SPA CABLE, AIRMAN 8			1
31	F.01U.359.674	NA	SPP PCBA NON-BOOM SIDE, STEREO, AIRMAN 8			1
32	F.01U.359.675	NA	SPP PCBA BOOM SIDE, STEREO, AIRMAN 8			1

1. Not shown.
2. Either part number is acceptable.

3. Acoustic cloth is included as part of this item.
4. The speaker assembly includes the speaker and the faceplate.
5. Only applies to earlier versions of the headset.
6. Changed in March 2021 from 180 degree rotation to 10 degree rotation.

5 Maintenance

The Airman 8 headset is designed so that ANR performance and boom microphone sensitivity can be adjusted as required to meet specification requirements. These headset adjustments are made in order to alter performance. All other maintenance requires replacement of parts, fixing open wires, or removing shorted wires. See specification instructions for ANR or boom microphone adjustment.

5.1 Recommended maintenance schedule



Notice!

Ear cushions, headband pads, and microphone windscreens are wear items. For proper headset performance, inspect and replace these items at regular intervals. See the maintenance schedule for more information. Failure to replace items when deterioration or damage is apparent diminishes headset performance.

Task	Per Use	Monthly	6 months
Check boom mic placement	X		
Check ear cup placement	X		
Check headband fit	X		
Inspect and clean connectors			X
Clean ear cushions		X	
Clean headband pad		X	
Check connection cable		X	
Inspect and replace windscreen			X
Inspect and replace ear cushions			X
Inspect and replace headband pad			X

5.2 Basic inspection

5.2.1 Physical inspection

Review all plastic parts for cracks or breaks

To review plastic parts, do the following:

- Note any parts which need to be replaced

Review all cables for obvious signs of damage to the insulating materials

To review cables, do the following:

- Look for any cables that have been pulled out of the housings.
- Look for any cables with unnatural or unusual bends or breaks.
- Note any cable assemblies that need to be replaced.

Review user replaceable items

To review user replaceable items, do the following:

- Check ear cushions.
- Check headband pads.
- Check microphone windscreen.
- Check clothing clips.
- Note any replaceable items that need to be replaced. Talk test.

Test

When performing a talk test, things to be aware of:

- Note any unusual or unexpected noises, static, and oscillations.
- Note any distorted audio.
- Turn ANR on and note noise reduction of fans, ambient noise etc.
- Turn ANR off and note noise levels return to normal.
- Verify sound is heard in both ears.

5.3 Microphone troubleshooting

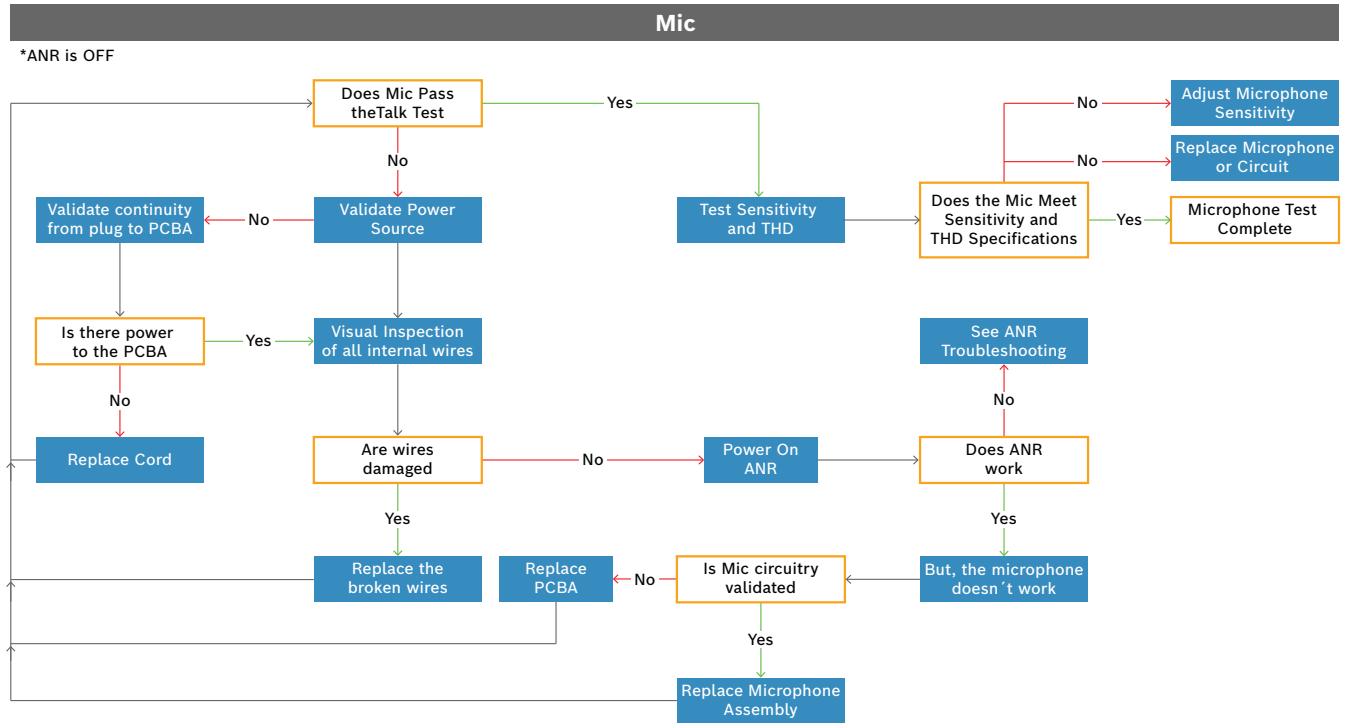

5.3.1 Validate continuity from plug to PCBA

To **validate continuity from the plug to the PCBA**, do the following:

1. Using an Ohmmeter, place one **probe** on the ring terminal of the plug.
2. Place the **other probe** at J1 on the PCBA.
3. Record the **measurement**.
4. Using an Ohmmeter, place **one probe** on the sleeve terminal of the plug.
5. Place the **other probe** at J2 on the PCBA.
6. Record the **measurement**.

If the reading is approximately zero, continuity is good.

If any other reading is seen, the continuity is bad. Replace the cable.

5.3.2 Validate mic circuitry

To **validate the mic PCBA**, do the following:

1. Construct a **test circuit**.

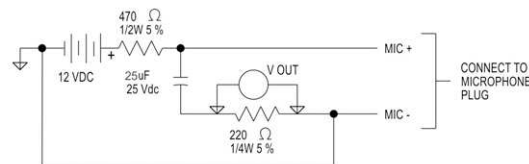

2. Connect the **test circuit to the microphone plug** of the headset.

For more information, see Connectors.

3. Test for an **audio signal**.

If audio signal is detected, the board is valid.

If audio signal is not detected, the board should be replaced.

5.3.3 Microphone/amplifier sensitivity test



Notice!

This headset was designed, tested, and approved to FAA TSO C139a. The TSO requires the headset meet the minimum performance specifications as defined in RTCA DO-214a. This document and specifications listed here reference the test procedures and equipment used as defined in these standards. Refer to the standard for details on how to perform individual tests.

To **test sensitivity of the microphone**, do the following:

1. Calibrate an **artificial mouth**.
2. Using the test circuit from the mic validation and TSO procedures, measure the **output** of the headset microphone with a true RMS AC voltmeter.

5.3.4 Microphone sensitivity adjustment

The microphone gain has been factory-adjusted to the nominal level required for normal radio operation. Microphone sensitivity adjusts by turning the gain adjustment control.

To **adjust the microphone**, do the following:

1. Rotate the **boom mic** clockwise until the microphone gain adjustment access hole is aligned and open.
2. Insert a **2mm x 0.5mm flat-bladed screwdriver** into the gain adjustment access hole.



Notice!

If the gain adjustment access hole is properly aligned, the screwdriver can be inserted approximately ½-inch into the hole. If not properly aligned, the screwdriver only inserts approximately 1/8-inch into the hole.

3. Turn the gain adjustment potentiometer **clockwise** to increase the gain.
- OR
- Turn the gain adjustment potentiometer **counterclockwise** to decrease the gain.

5.3.5 Microphone total harmonic distortion (THD) test

1. Calibrate the sound pressure to be 114 dB SPL at 6 mm from an artificial mouth.
2. Measure the THD of the microphone placed at that location using the same test circuit. It meets the TSO spec when THD is less than 5% from 350 Hz to 6000 Hz.

5.4 Speaker troubleshooting

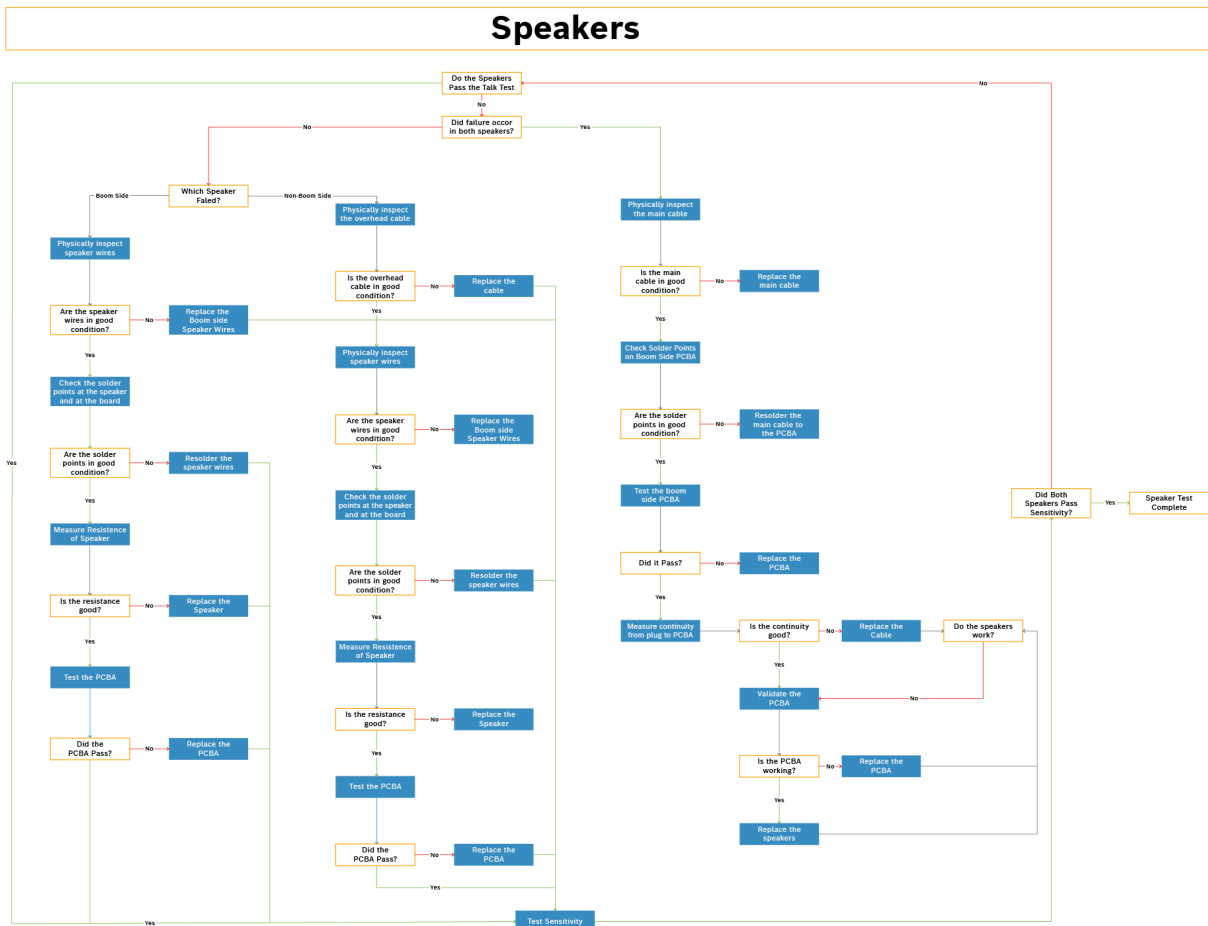

5.4.1 Speaker sensitivity and frequency response verification

Notice!



This headset was designed, tested, and approved to FAA TSO C139a. The TSO requires the headset meet the minimum performance specifications as defined in RTCA DO-214a. This document and specifications listed here reference the test procedures and equipment used as defined in these standards. Refer to the standard for details on how to perform individual tests.

All models tested, unless noted otherwise.

Transducer Type:	Dynamic
------------------	---------

Transducer:	600Ω
Impedance (at the earphone plug):	Must meet standards outlined in the specifications table in either the technical manual or the technical data sheet.
Sensitivity:	
Frequency Response:	

5.4.2 Measure the resistance (plug to PCBA)

To **measure the resistance**, do the following:

- Using an ohmmeter, place one **probe on J5**.
- Place the other **probe on J6 or J17**.
If measured at $600\Omega \pm 20\%$, continuity is good.
If measured differently, either one of the speaker paths is defective or there is a short in the speaker paths.

5.4.3 Validate the boom side PCBA

To **validate the boom side PCBA**, do the following:

- On the boom side PCBA, send a **1kHz sine wave, 1Vrms signal** from J5 to J6.
- Verify the **ANR switch is in the off position**.
- Using an oscilloscope, place a probe at **J13**.
- Place the other probe at **J14**.
If a signal is found, the board is good and if no sound is heard from the speaker, the speaker or wiring is bad. Determine if the speaker needs to be replaced or the wires need re-soldering.
If a signal is not found, the board is not good and should be replaced.

5.4.4 Validate the non-boom side PCBA

To **validate the non-boom side PCBA**, do the following:

- On the non-boom side PCBA, send a **1kHz sine wave, 1Vrms signal** from J5 to J6.
- Verify the **ANR switch is in the off position**.
- Using an oscilloscope, place a probe at **J13**.
- Place the other probe at **J14**.
If a signal is found, the board is good and if no sound is heard from the speaker, the speaker or wiring is bad. Determine if the speaker needs to be replaced or the wires need re-soldering.
If a signal is not found, the board is not good and should be replaced.

5.5 ANR troubleshooting

ANR

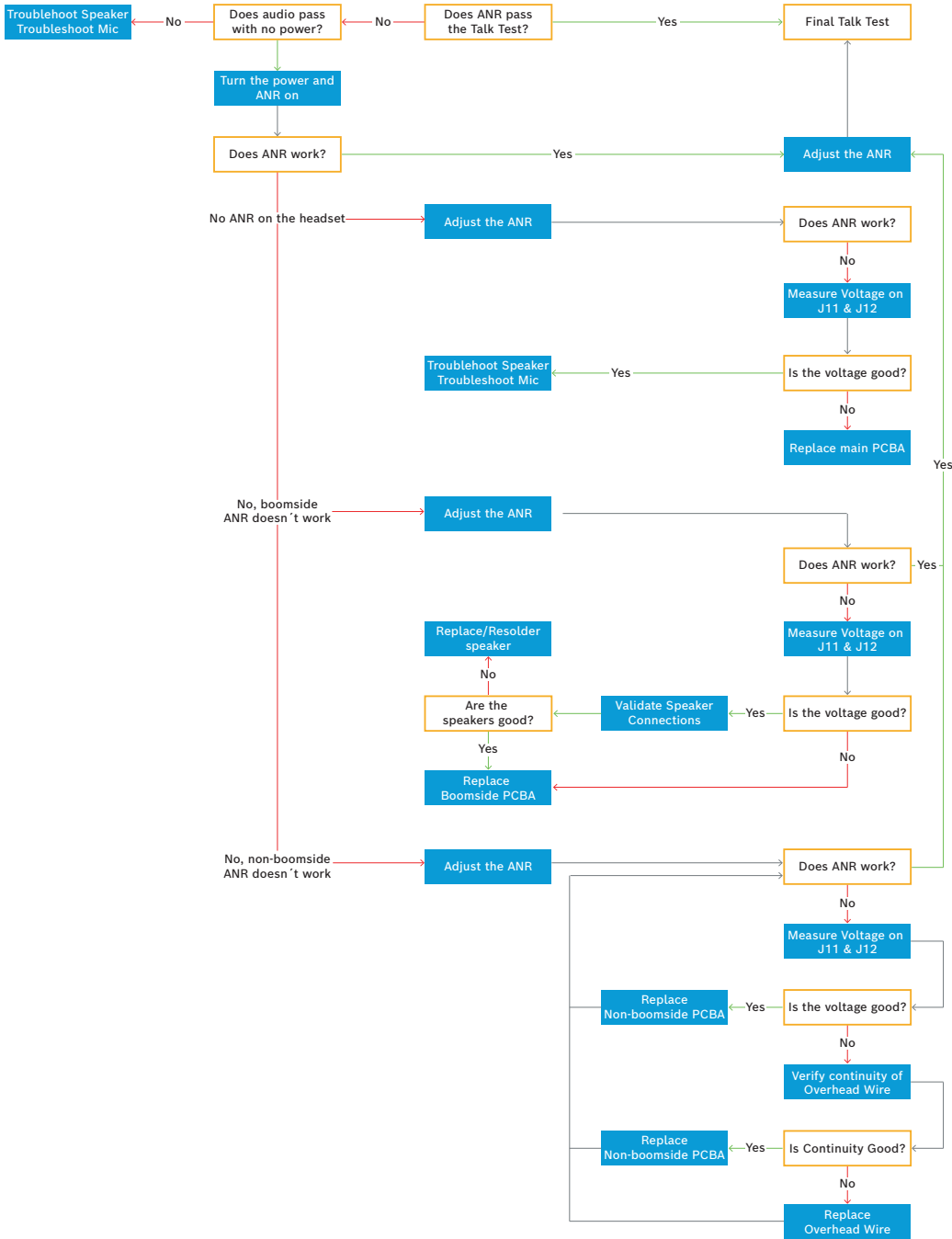

5.5.1 Measuring ANR circuit voltages and switch function



Notice!

This headset was designed, tested, and approved to FAA TSO C139a. The TSO requires the headset meet the minimum performance specifications as defined in RTCA DO-214a. This document and specifications listed here reference the test procedures and equipment used as defined in these standards. Refer to the standard for details on how to perform individual tests.



Notice!

Minimum attenuation requirements are not requirements of FAA TSO. To achieve the maximum attenuation, Bosch approved test system is required.

To **measure voltage and switch function on the boom side**, do the following:

1. Verify the **headset main cable plugs are on**.
2. Using a voltage meter, place the **ground probe at J10**.
3. Place the **positive probe on TP14**.

If the measurement is 3.3Vdc, the power regulator is good. If the measurement is anything other than 3.3Vdc $\pm 10\%$, the power regulator is bad. Replace the board.

To **measure the switch functionality on the boom side**, do the following:

1. If the regulator is good, verify the **ANR switch is in the off position**.
2. If the boom side is good, place the **positive probe at J11 on the non-boom side**.
If the measurement is near 0, the switch is open
3. Move the **ANR switch to the on position**.

If the measurement is at 3.3Vdc $\pm 10\%$, the switch is good. If the measurement is anything else, the switch is bad. Replace the board.

To **measure the fail-safe control logic for ANR**, do the following:

1. Verify the **ANR switch is in the on position**.
2. Place the **voltage meter probe at J12** on the boom-side.

If the measurement is greater than -6Vdc, the fail-safe logic is working properly. If the measurement is anything below -6Vdc, the fail-safe logic is not working. Replace the board.

To **measure voltage and switch function on the non-boom side**, do the following:

1. Place the **positive probe at J11**.
2. Move the **ANR switch to the on position**.

If the measurement is near zero, the switch is open.

If the measurement is at 3.3Vdc $\pm 10\%$, the switch is good. If the measurement is anything else, the switch is bad. Replace the board.

To **measure the fail-safe control logic for ANR**, do the following:

1. Verify the **ANR switch is in the on position**.
2. Place the **voltage meter probe at J12 on the non-boom-side**.

If the measurement is greater than -6Vdc, the fail-safe logic is working properly. If the measurement is anything below -6Vdc, the fail-safe logic is not working. Replace the board.



Notice!

For board replacement, contact Bosch ASA or a Bosch certified facility for replacement and adjustment.

5.6 Cleaning the headset and connectors

**Caution!**

Do not allow alcohol or any liquid to touch the speaker or microphone element directly.

To **clean the headset**, do the following:

- ▶ Using a mild detergent with water and a soft towel, or isopropyl alcohol wipes, clean the plastic and metal headset parts.
-

**Caution!**

Do not soak or allow liquid to puddle on the unit.

5.7 Cleaning the ear cushions and headband pads

**Caution!**

Do not soak the cushions or pads.

To **clean the ear cushions and headband pad**, do the following:

- ▶ Using a damp (not wet) soft towel or isopropyl alcohol wipe, gently wipe the **ear cushions and headband pad** thoroughly.
-

5.8 Replacing ear cushions and headband pads

To ensure optimal product performance, it is recommended you replace ear cushions and headband pads periodically (every six months, or sooner if needed). See Recommended maintenance schedule. For detailed instructions on replacing the ear cushions, refer to Ear cushion replacement. For detailed instructions on replacing the headband pads, refer to Headband pad and headband pad replacement.

5.9 Installing and replacing the hygienic covers

**Notice!**

Two hygienic covers are included with the headset. However, extra hygienic covers can be purchased separately.

To **replace the hygienic covers**, do the following:

1. Grasp the **edge of the hygienic cover** where it folds into the slot on the ear cup.
 2. Gently pull the **hygienic cover** up and away from the ear cup.
 3. Starting at the top of the ear cup, carefully work the **cover** around the ear cup until it is in place.
-

5.10 Replacing the windscreen

The foam windscreen can be cleaned using low-pressure air to blow contaminants off the exterior. If low-pressure air does not provide effective results, the windscreen should be replaced.

**Caution!**

Do not use any liquid on the foam windscreen.

To **remove the windscreen**, do the following:

- ▶ Grasp the **microphone windscreen** and gently pull away from the microphone.

To **replace the windscreen**, do the following:

- ▶ Slide the **new windscreen** over the microphone.

5.11

Headset storage

To **store the headset**, it is recommended to do the following:

1. Move the **boom mic above the headband**.
2. Coil the **cord** into a loop.
3. Place the **coiled cord and headset** in the carrying case.

**Notice!**

We tested this product for environmental tolerance, but it performs best and lasts longest when you store it in a climate-controlled environment. Operating or storing the product for long periods in non-climate-controlled conditions can cause unintended and premature component degradation.

6 Disassembly

The following procedure describes the complete disassembly of the Airman 8 headset.

**Notice!**

The removal process requires the following steps to be followed in the order described. Assembly is the reversal of the disassembly procedure. Please take care when disassembling to note details that may be required in the reassembly process, such as the locations of disconnected wires.

When soldering, be careful not to touch the plastic housing of the headset/headphone with the soldering iron.

**Notice!**

Only disassemble parts that are necessary for the repair.

6.1 Remove the headband cover clips (if present)

To remove the headband cover clips, do the following:

- ▶ Using a flat-head screwdriver, carefully pry the clip from the headband.

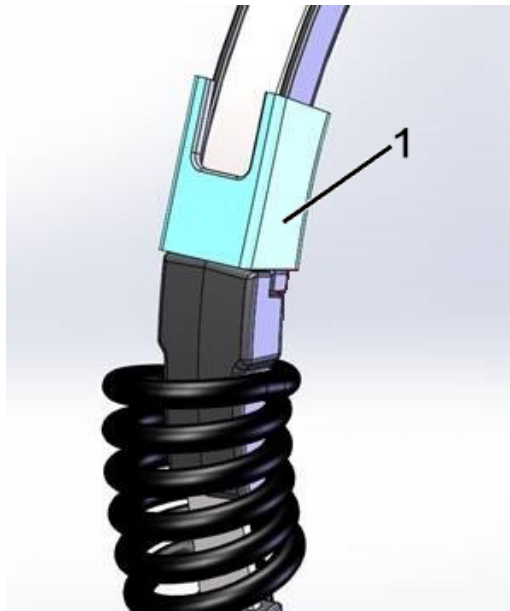
**Notice!**

Some headsets have a snap feature (2) at each end of the headband cover. If this feature (highlighted in white) is present, the external clips (1) are not used.

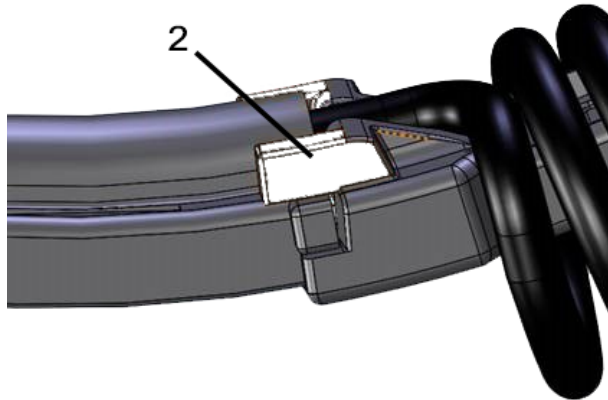

6.2 Ear cushion replacement

To ensure optimal product performance, replace cushions and pads periodically.

For the recommended maintenance schedule, please refer to Recommended maintenance schedule.

To **replace the ear cushions**, do the following:

1. Remove the **hygiene covers**, if installed.
2. Grasp the **edge of the ear cushion** where it folds into the slot on the ear cup.
3. Gently pull the **ear cushion up and away** from the ear cup.

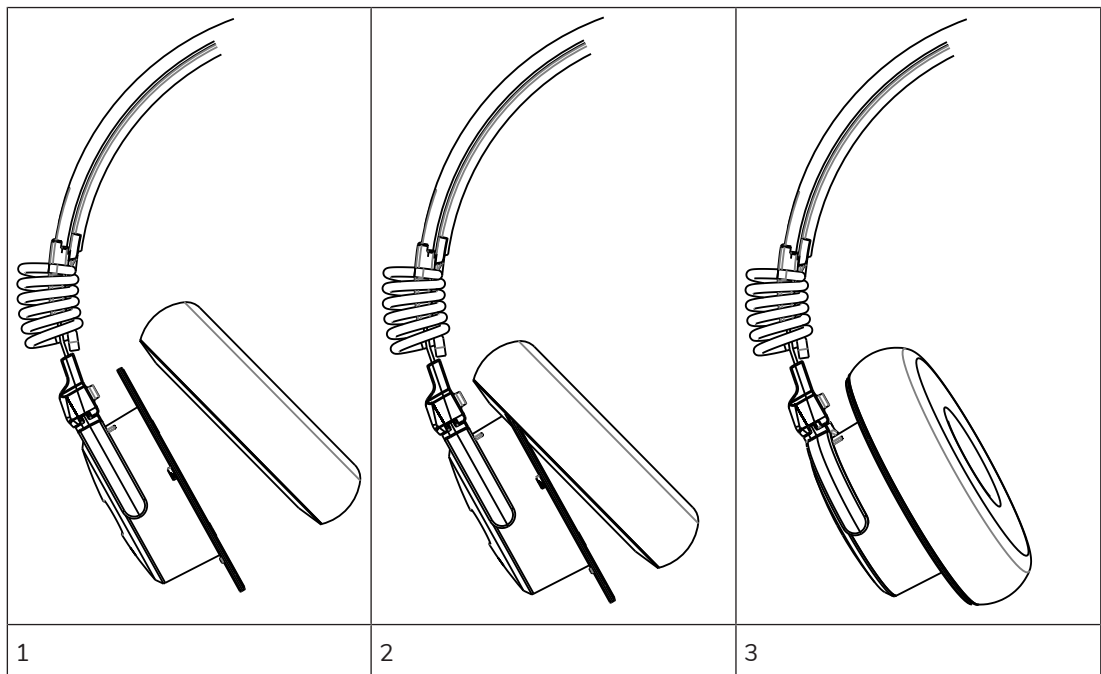

1. Starting at the **top of the ear cup** (1), carefully work the **cushion around the cup** (2) until it is **in place** (3).
2. Verify the **replacement** is acceptable by visually inspecting around the cushion before use.

6.3 Headband pad and headband pad replacement

To **replace the headband pads**, do the following

Early version headband

1. Carefully remove the **headband clips**. See *Remove the headband cover clips (if present)*, page 23.
2. Gently pull the **headband cover** away from the headband.
3. Starting at either side of the headband, carefully work the **replacement cover** around the metal headband until it is in place.

Current version headpad holder and headpad

To **replace the headpad holder**, do the following:

1. At one end of the headpad holder, carefully pry the **holder** from the headband cover.

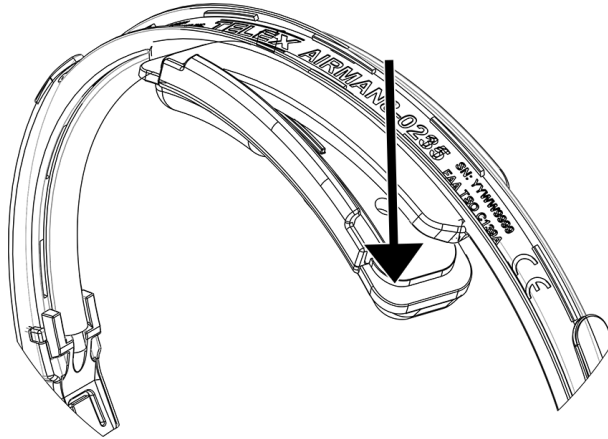

Notice!

Carefully twisting slightly on the headpad holder can help remove the piece easier.

2. With the new headpad holder, hook **one side of the headpad holder** over the headband cover.
3. Snap **the other side of the headpad holder** in place. Be sure the headpad holder edge is over the headband cover.

To **replace the headpad**, do the following:

1. Grasp the **edge of the headband pad**.
2. Gently pull the **headband pad** away from the headpad holder.
3. Remove the **paper** from the sticky side of the new headband pad.
4. Align the **headband pad** with the recessed area on the headpad holder.
5. Firmly press the **headband pad** into place.

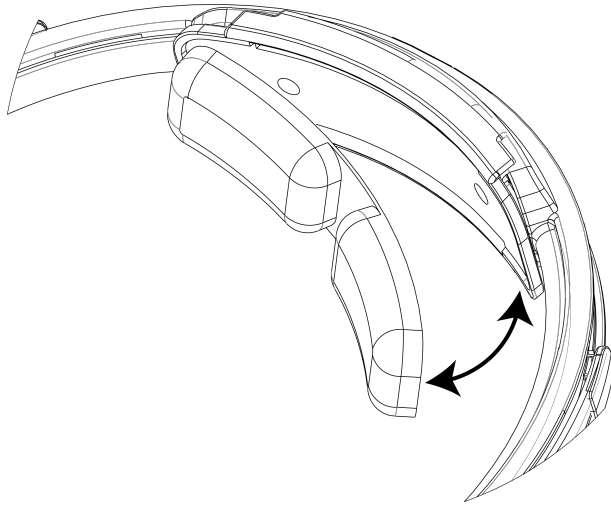

6.4 Remove the mic prefilter

To remove the **prefilter**, do the following:

- ▶ Carefully pry the **prefilter** from the mic.

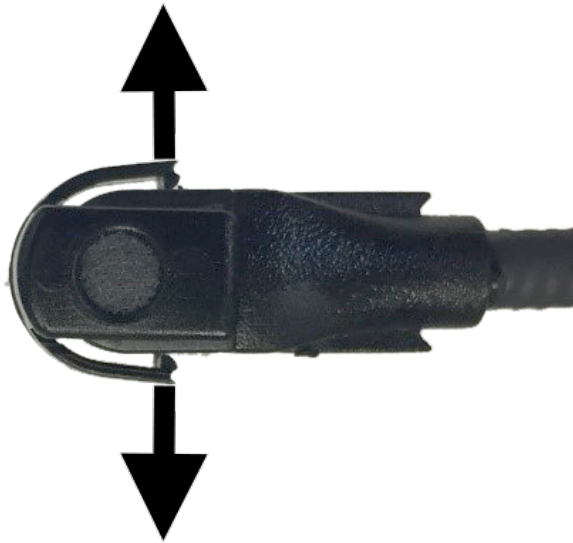

6.5 Remove the yoke assembly from the headband assembly

To remove the **yoke assembly from the headband assembly**, do the following:

1. Use a fingernail to lift the **bottom edge of the black plastic spacer**.
2. Swivel the **black plastic spacer** to the side and remove it from the assembly.



3. Slide the **yoke assembly** off of the headband.

6.6 Boom side disassembly

To **remove the speaker assembly and sleeve**, do the following:

1. At the same time, push the **two retaining cams** located in the speaker assembly out of the way.

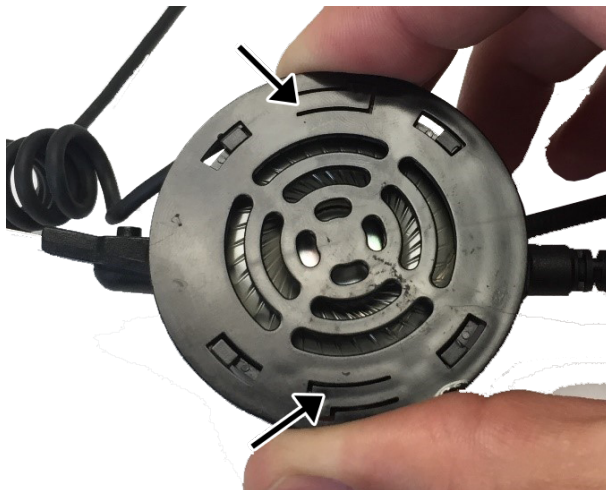

2. Rotate the **speaker faceplate** approximately 15° clockwise.
3. Using a T-5 screwdriver, remove **three screws** (as shown).

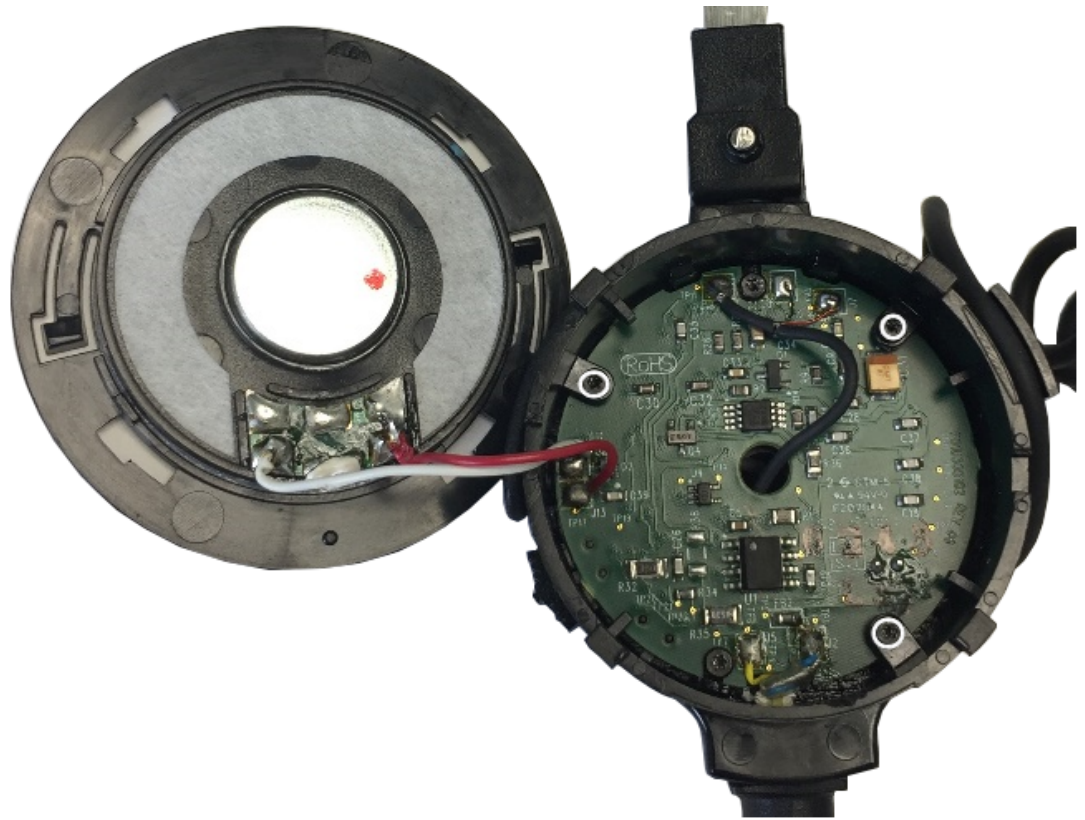

4. Remove the **house and the yoke/glider assembly**.



5. Using a T-5 screwdriver, remove **two screws** (as shown).



6. Remove the PCBA.
7. Using a soldering iron, carefully **disconnect the wires** from the speaker, overhead cord, boom mic assembly, and ANR mic solder terminals, as needed.



Notice!

Take care to avoid touching the plastic housing with the soldering iron.

6.7

Non-boom side disassembly

To remove the speaker assembly and sleeve, do the following:

1. Pushing the two retaining cams simultaneously on the speaker assembly, rotate the **speaker faceplate** approximately 15° clockwise.



Notice!

To avoid pulling the wires from the board, do not pull the speaker assembly more than 12mm from the ear shell.

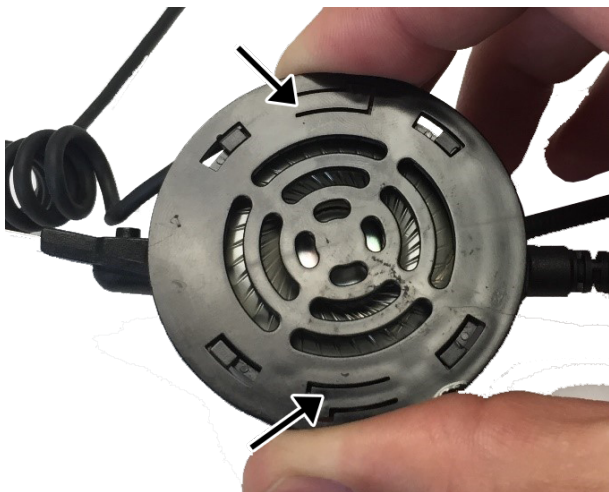

- 2. Using a T-5 screwdriver, remove **three screws** (as shown).

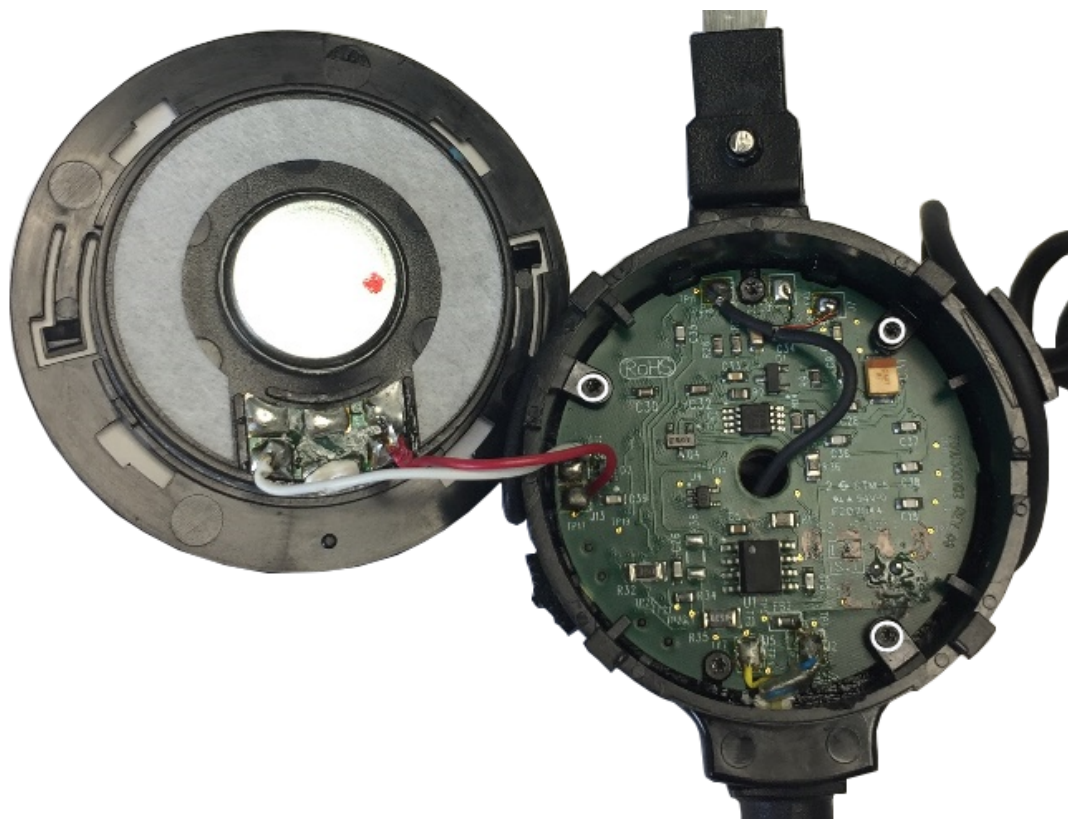

- 3. Remove the **house and the yoke/glider assembly**.



4. Using a T-5 screwdriver, remove **two screws** (as shown).



5. Remove the **PCBA**.
6. Using a soldering iron, carefully disconnect the **wires from the speaker and overhead cord, and ANR mic solder terminals**, as needed.

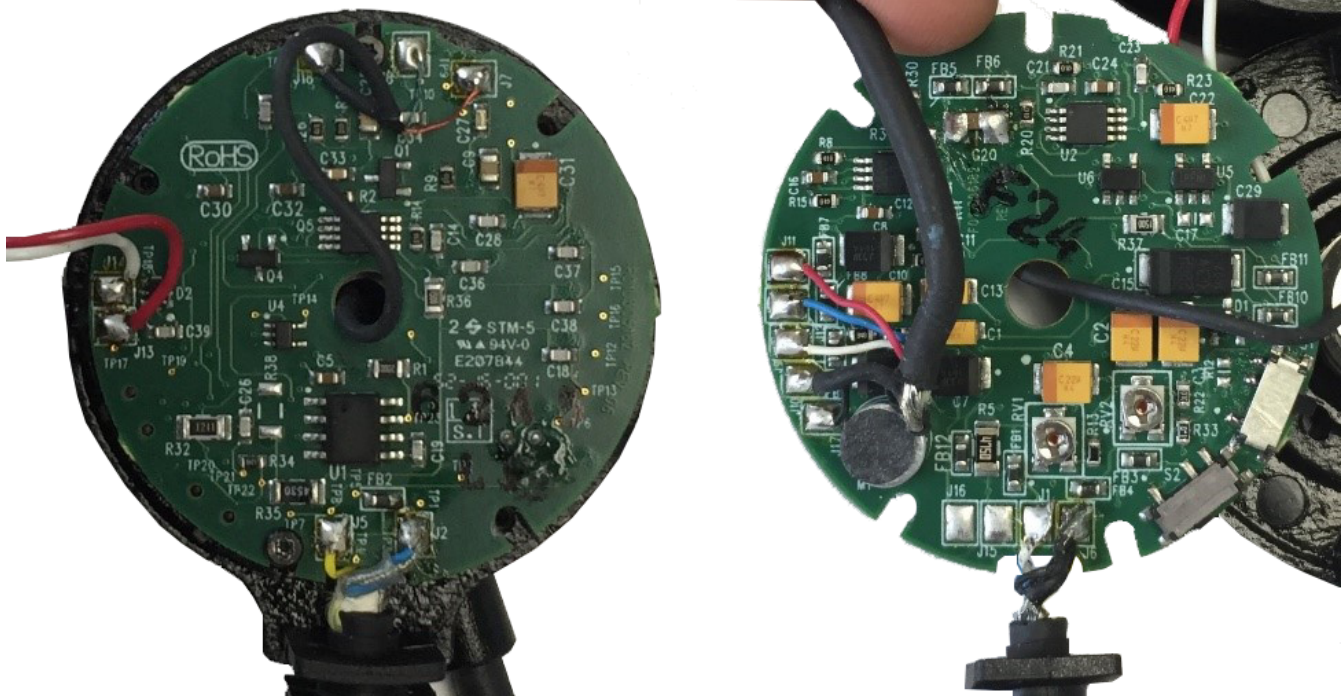

Notice!

Take care to avoid touching the plastic housing with the soldering iron.

7 Assembly

7.1 Boom side assembly

To **assemble the boom side assembly**, do the following:

1. Solder the **overhead cord** to the PCBA.

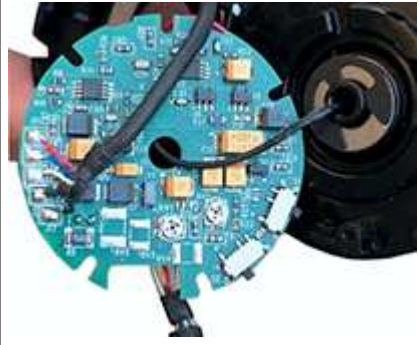
J11	Red	
J12	Blue	
J9	White	
J10	Shield	
J17	Black	

2. Solder the **cable assembly** to the PCBA.
3. Thread the **boom mic wires** through the center hole.
4. Solder the **boom mic wires to the PCBA**.

J7	Red	
J8	Green	
J18	Shield	



Notice!

Use shield as an anchor point so there is slack on smaller wires.

5. Using the two shorter screws, attach the **PCBA to the boom mic assembly** (1).

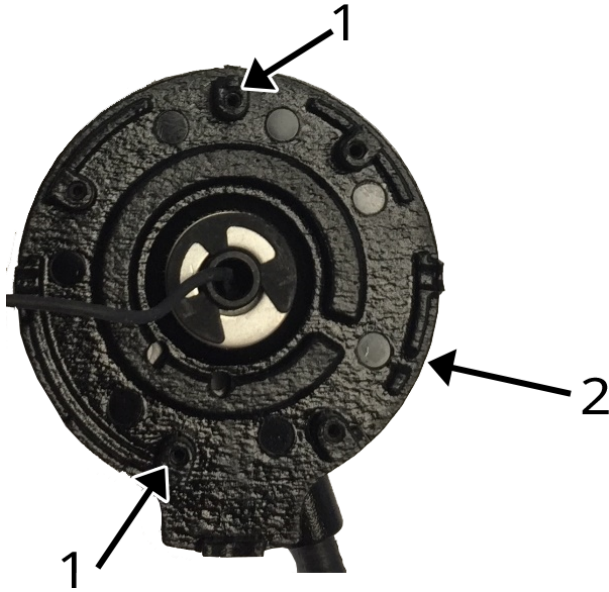

Notice!

Take care to route the overhead cord and headset cord through the corresponding grooves provided on the boom (2).

6. Verify the **overhead cord** is not caught between the ANR mice (3) and the boom mic housing. Position 1 is correct; position 2 is incorrect.

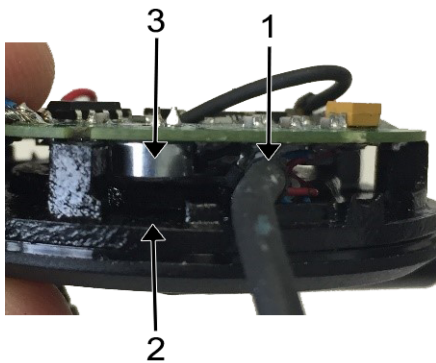

7. Solder the wires to the speaker.



Notice!

Align the red wire with the polarity dot on the speaker.

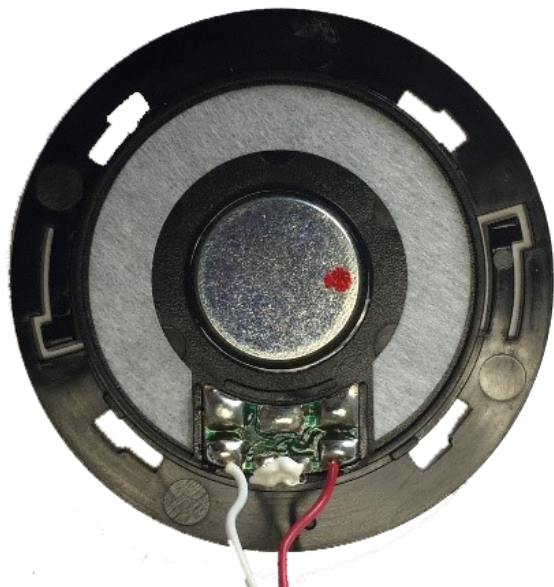

8. Route the **speaker wires** through the housing and solder to the PCBA.

J13	Red
J14	white

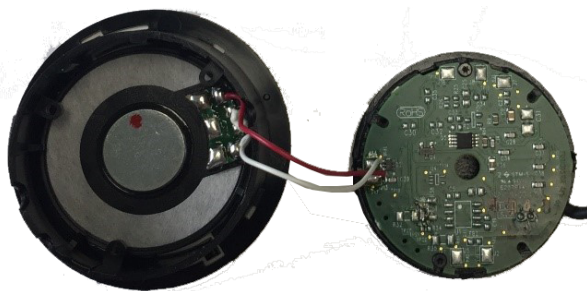

9. Place **yoke** on the housing.



Notice!

Take care to verify the orientation of the yoke, because it does not rotate 360°.



10. Place the **switch cover** on the ANR switch.



Notice!

The side with the deep grooves goes toward the speaker.

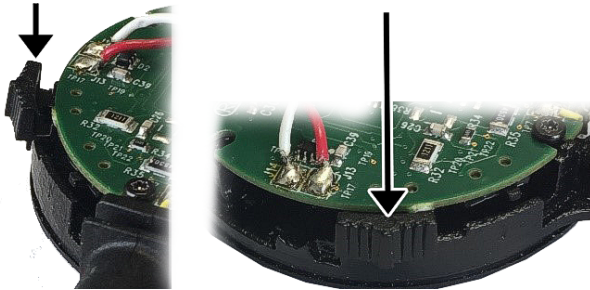

11. Place the **housing** on the boom mic assembly.



Notice!

Make sure the overhead cord is in the correct slot and the jacket is fully inside the housing. Also, make sure the headset cord is properly located in the housing.

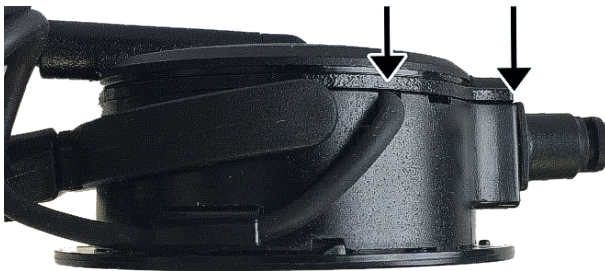

12. Using a T-5 screwdriver, replace the **three screws** (as shown) to attach the yoke and housing to the PCBA.

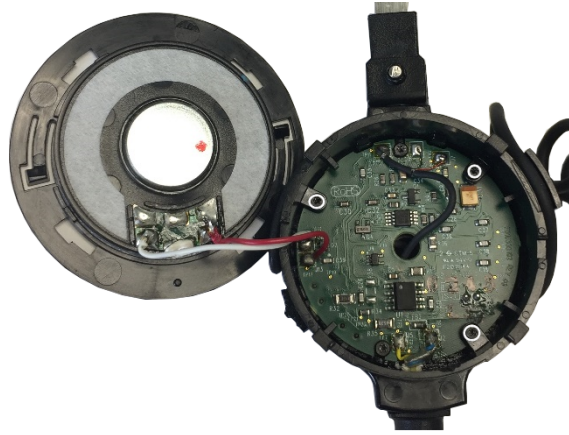

13. Position the **overhead cord** in the guide, and then align the knob of the faceplate toward the bottom.

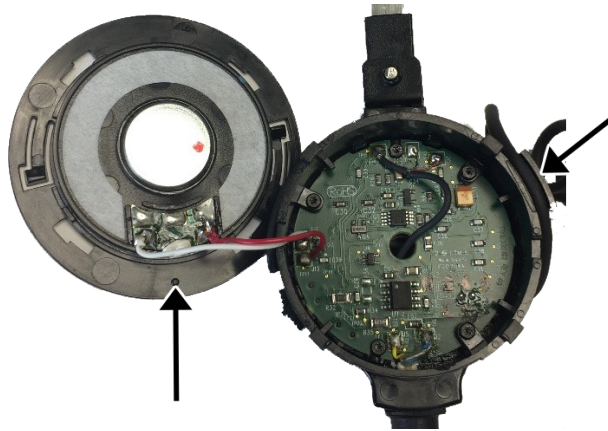

14. Align the **four tabs** on the faceplate, and then rotate counterclockwise to lock.

**Notice!**

Verify all four tabs engage and retaining tabs are in the groove.

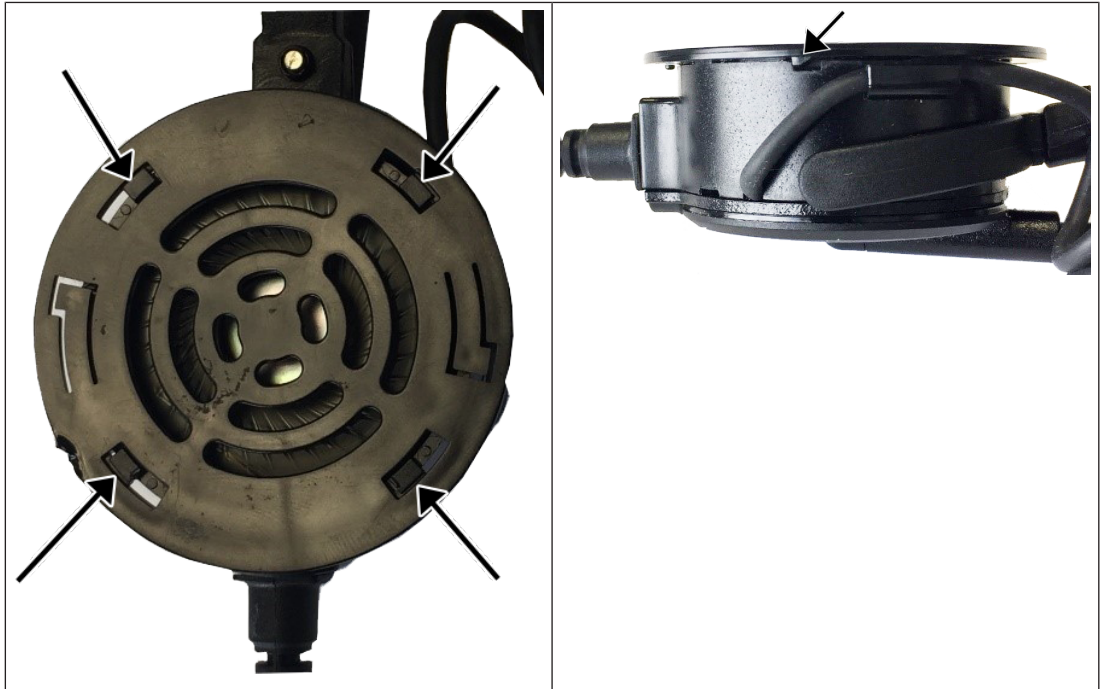

15. Carefully wind the **overhead cord** around the glider.



7.2

Non-boom side assembly

To **assemble the non-boom side assembly**, do the following:

1. Solder the **overhead cord** to the PCBA.

J11	Red	
J12	Blue	
J9	White	
J10	Shield	
J17	Black	

2. Using the two shorter screws, attach the **PCBA** to the cover.

**Notice!**

The location of the alignment posts (1) and the path for the overhead cord (2)

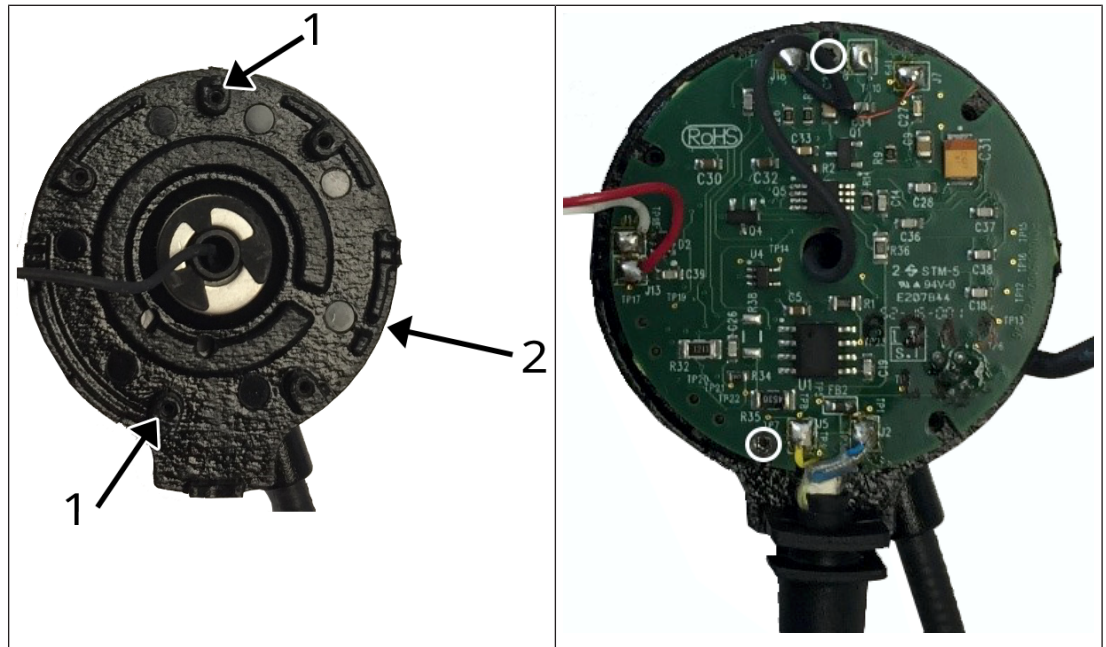

3. Solder the **wires** to the speaker.

**Notice!**

Align the red wire with the polarity dot on the speaker (as shown)

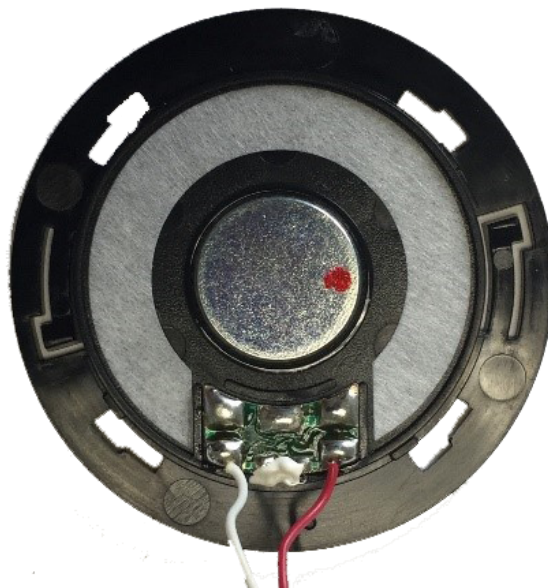

4. Route the **speaker wires** through the housing and solder to the PCBA.

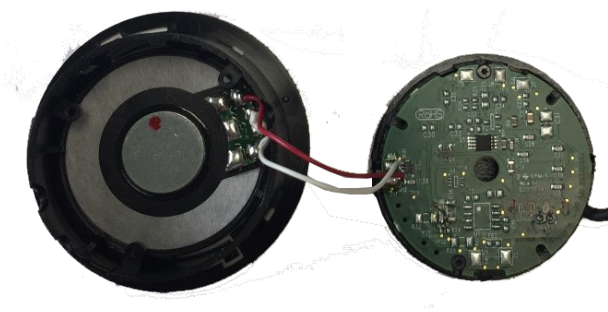

J13	Red
J14	White

5. Place **yoke** on the housing.



Notice!

Take care to verify the orientation of the yoke, because it does not rotate 360°.

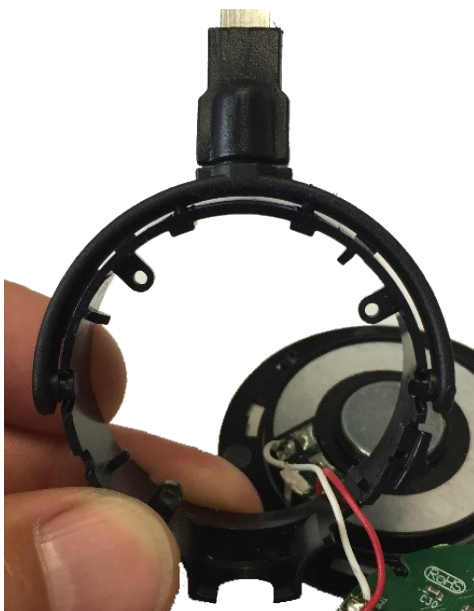

6. Place the housing on the boom mic assembly.

7. Place the **cover** on the housing.



- 8. Using a T-5 screwdriver, replace the **three screws** (as shown) to attach the yoke and housing to the PCBA.

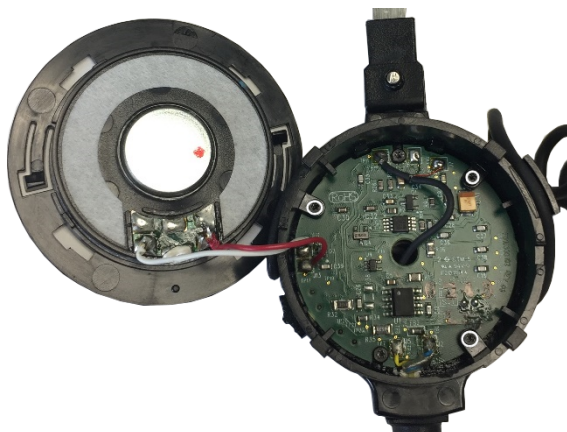

- 9. Position the **overhead cord** in the retaining clip and align the **knob** of the faceplate toward the bottom.

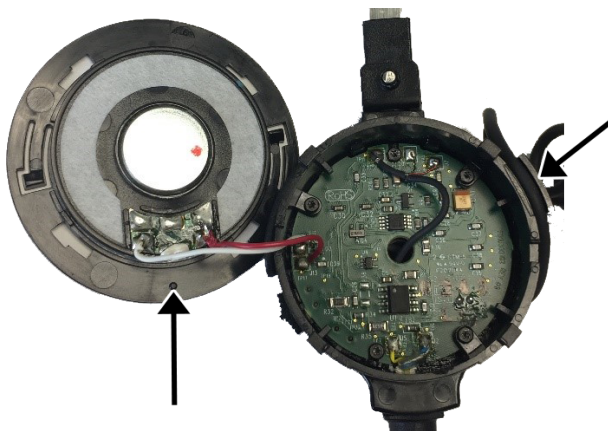

- 10. Align the **four tabs** on the faceplate, and then rotate counterclockwise to lock.



Notice!

Verify all four tabs engage and retaining tabs are in the groove.

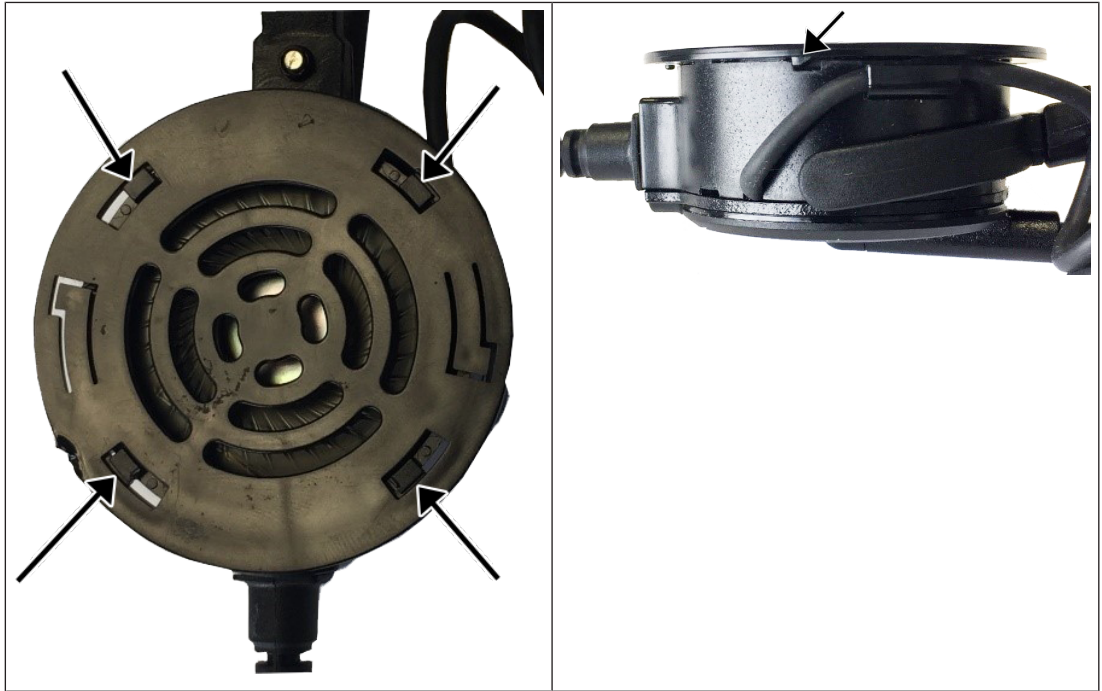

11. Carefully wind the **overhead cord** around the glider.



7.3 Attach the prefilter

To **attach the prefilter**, do the following

- ▶ Carefully clip the **prefilter** to the mic.

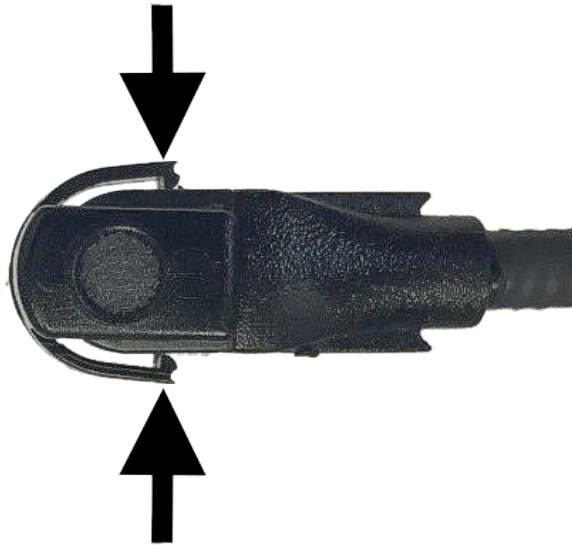

7.4 Reinstall the headband cover

To **reinstall the headband cover**, do the following:

1. Take care to verify the **overhead cord** lays between the guides.
2. Ensure the **cover** fully encloses around the headband at both sides.

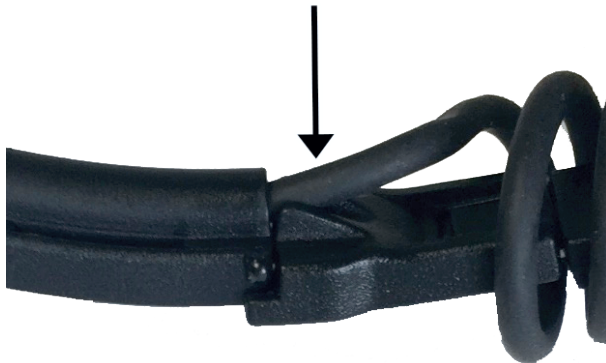

7.5 Replace the yoke assembly on the headband assembly

To **replace the yoke assembly on the headband assembly**, do the following:

1. Slide the **yoke assembly** onto the headband.
2. Place the **glider stop** in the appropriate hole on the glider.
3. Swivel the **spacer** in line with the glider.
4. Click the **bottom edge of the black plastic spacer** into the retaining hole.

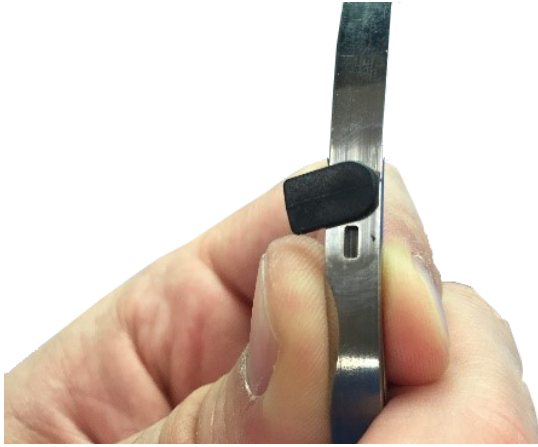

8 Wiring Diagrams and Connectors

8.1 Wiring Diagram AIRMAN8-2010 and AIRMAN8-0211

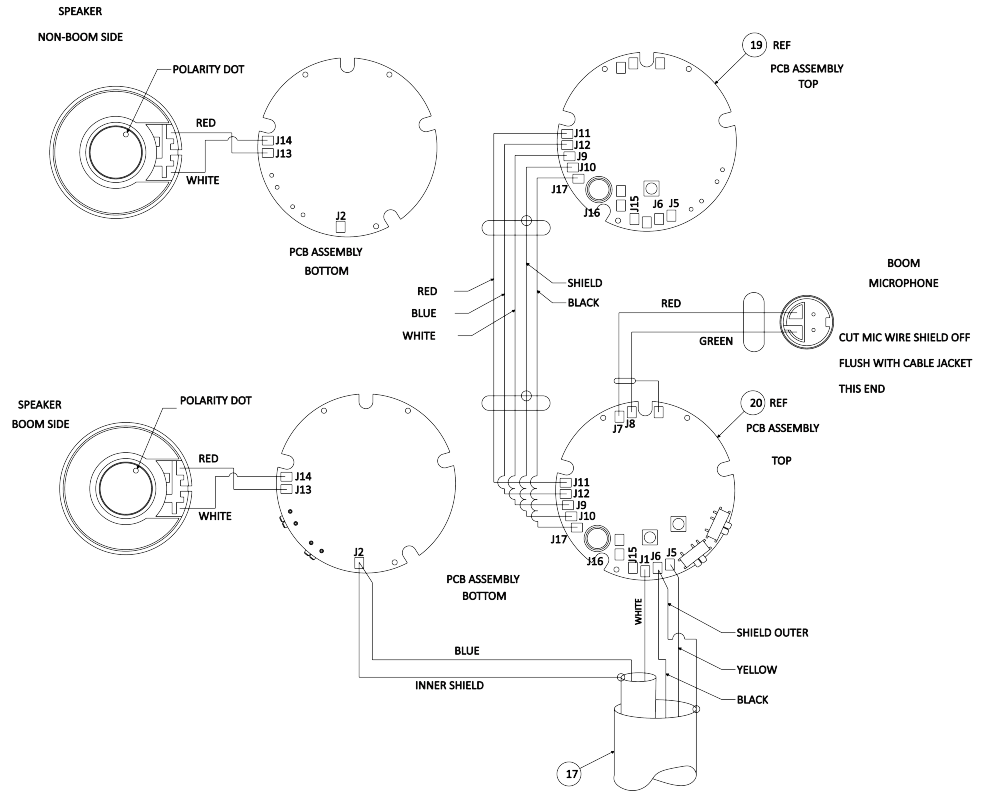

	Wire	Notes
J15	No connection	Outside (mic side)
J1	White	Outside (mic side)
J5	Yellow	Inside
J6	Outer shield + black	Inside
J2	Inner shield + blue	Inside
J16	No connection	Inside

8.2 PJ-068/PJ055 Connector Diagram for AIRMAN8-0210

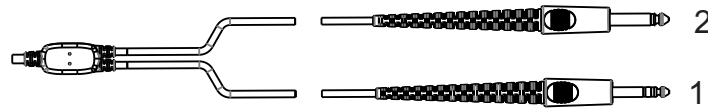

Figure 8.1: PJ Connector

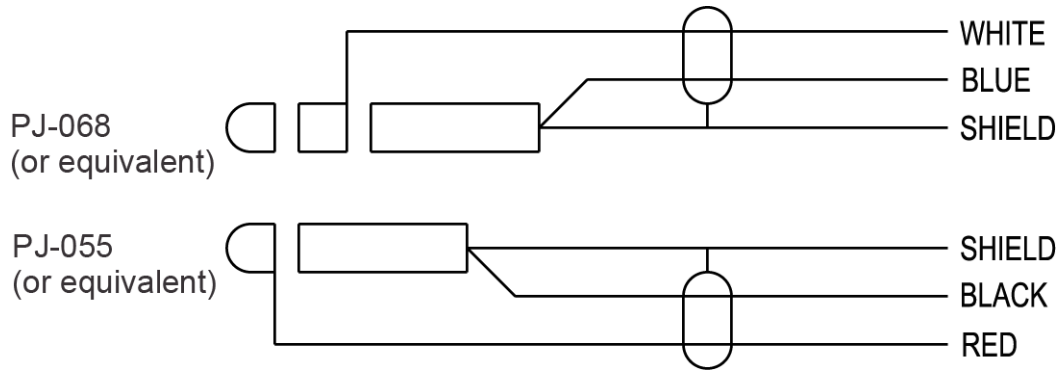

Figure 8.2: Wiring Diagram

PJ-068 or equivalent	Description	Wiring Color
Tip	Not Used	
Ring	Mic Signal	White
Sleeve	Mic GND	Blue/Shield

PJ-055 or equivalent	Description	Wiring Color
Tip	Headphone Signal	Red
Sleeve	Headphone GND	Black/Shield

8.3

XLR Connector Diagram for AIRMAN8-0210

5-Pin XLR Aircraft Cable

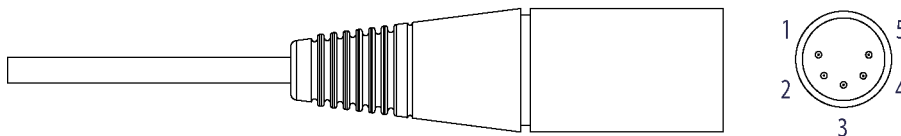

Figure 8.3: 5-pin XLR Connector

Pin	Description	Color
1	Headphone Signal	Red
2	Headphone GND	Black/Outer Shield
3	Mic Power and Signal	White
4	Mic GND and ANR Return	Blue/Inner Shield
5	No Connection	

Table 8.1: Airman8P-0211

8.4

Stereo Connector Diagram for AIRMAN8-0235

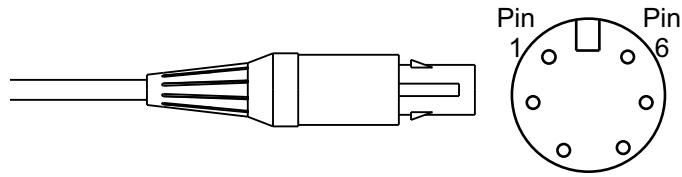

Figure 8.4: 6-pin Male Stereo Connector

Pin	Connection
1	No connection
2	Shield (outer) - Black
3	Left speaker - Yellow
4	Right speaker - Green
5	Mic (+) - White
6	Mic (-) - Blue (inner shield)



Electro-Voice Dynacord LLC

130 Perinton Parkway

Fairport, NY 14450

USA

www.telex.com

© Electro Voice Dynacord 2026

EU importer:

EVI Audio GmbH

Sachsenring 60

94315 Straubing

Germany

© EVI Audio GmbH, 2026



202602021944